

Stainless Steel Regulators

The range of Stainless Steel FRLs are ideal for use in the food industry, the petrochemical or process industries or any application in a particularly harsh or aggressive environment.

- Stainless steel construction handles most corrosive environments
- Large diaphragm to valve area ratio for precise regulation and high flow capacity
- Meets NACE specifications MR-01-75/ISO 15156



WARNING

Product rupture can cause serious injury.
 Do not connect regulator to bottled gas.
 Do not exceed maximum primary pressure rating.

CAUTION:

REGULATOR PRESSURE ADJUSTMENT -

The working range of knob adjustment is designed to permit outlet pressures within their full range. Pressure adjustment beyond this range is also possible because the knob is not a limiting device. This is a common characteristic of most industrial regulators, and limiting devices may be obtained only by special design. For best performance, regulated pressure should always be set by increasing the pressure up to the desired setting.

Operating information

	PR354 & PR11	PR364 & PR10
Operating pressure:	300 PSIG Max (20.7 bar)	300 PSIG Max (20.7 bar)
Operating temperature:	0°F to 180°F (-18°C to 82°C)	0°F to 150°F (-18°C to 66°C)
Flow / SCFM (dm ³ /s):	12 (5.66)	80 (37.76)

Regulators



Port size	Adjustment type	Flow SCFM (dm ³ /s)	Part number 0 to 125 PSIG
1/4	Knob version	12 (5.66)	PR364-02CSS
1/4	All metal version	12 (5.66)	PR354-02CSS
1/2	Knob version	80 (37.76)	PR10-04CSS
1/2	T-handle version	80 (37.76)	PR11-04CSS

Service kits

Description		PR354	PR364	PR10	PR11
Bonnet Kit		CKR354YSS	CKR364Y-1SS	CKR10YSS	CKR11YSS
Gauge, stainless – 160 PSIG (0 to 1100 kPa)	1-1/2" Face	K4515N14160SS	K4515N14160SS		
	2" Face			K4520N14160SS	K4520N14160SS
Panel mount bracket (stainless)		161X57-SS	161X57-SS	R10Y57-SS	R10Y57-SS
Panel mount nut –	stainless	R05X51-SS	R05X51-SS	R10X51-SS	R10X51-SS
	plastic	R05X51-P	R05X51-P	R10X51-P	R10X51-P
Pipe nipple, 316 stainless steel		616Y28-SS	616Y28-SS	616A28-SS	616A28-SS
Service Kit –	relieving	RKR364YSS	RKR364YSS	RKR10YSS	RKR10YSS
	non-relieving	RKR364KYSS	RKR364KYSS	RKR10KYSS	RKR10KYSS
Springs –	0-25 PSIG range	SPR-375-2-SS	SPR-375-2-SS	SPR-388-1-SS	SPR-388-1-SS
	0-60 PSIG range	SPR-376-1-SS	SPR-376-1-SS	SPR-389-1-SS	SPR-389-1-SS
	0-125 PSIG range	SPR-377-1-SS	SPR-377-1-SS	SPR-390-1-SS	SPR-390-1-SS

Most popular.

PR354

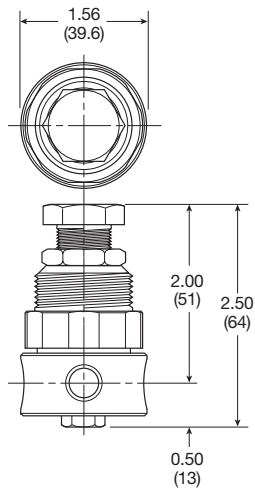

PR364

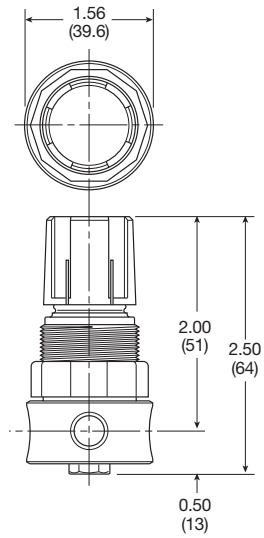

PR10

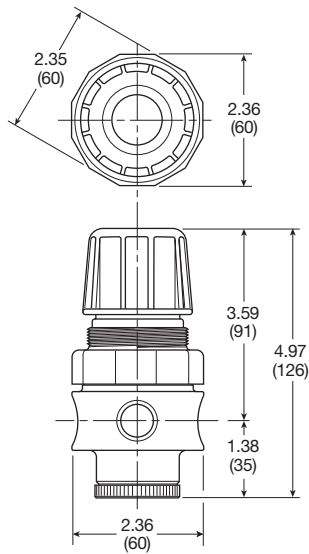

PR11

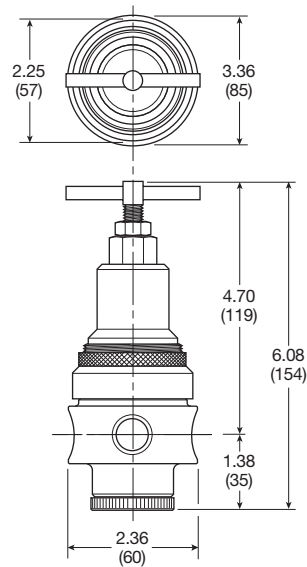

Specifications

Description	PR354	PR364	PR10	PR11
Gauge port	1/4	1/4	1/4	1/4
Operation	Fluorocarbon diaphragm	Fluorocarbon diaphragm	Fluorocarbon diaphragm	Fluorocarbon diaphragm
Port threads	1/4	1/4	1/2	1/2
Weight	0.5 lb. (0.23 kg)	0.5 lb. (0.23 kg)	1.79 lb. (0.81 kg)	1.79 lb. (0.81 kg)

Material specifications

Description	PR354	PR364	PR10	PR11
Adjustment mechanism / springs:	316 stainless steel	316 stainless steel	316 stainless steel	316 stainless steel
Adjusting knob	316 stainless steel	Polypropylene		
Body / poppet	316 stainless steel	316 stainless steel	316 stainless steel	316 stainless steel
Bonnet	316 stainless steel	Acetal	Acetal	316 stainless steel
Bottom plug	316 stainless steel	316 stainless steel	316 stainless steel	316 stainless steel
Seals	Fluorocarbon	Fluorocarbon	Fluorocarbon	Fluorocarbon

