

PR10, PR11 Regulator – Standard

Symbol

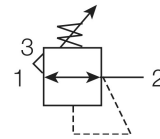

- Stainless steel construction handles most corrosive environments
- Large daphragm to valve area ratio for precise regulation and high flow capacity
- Meets NACE specifications MR-01-75/ISO 15156
- Low temperature version available
- High flow: 1/2" – 37.75 dm³/s[§]

Options:

PR10		G		04		C				SS	
Series		Port size		Port size		Pressure range		Options		Material	
Standard knob	PR10	BSPP	G	1/2"	04	0 - 4.1 bar	B	Relieving	Blank	Stainless steel	SS
Stainless steel tee handle	PR11	NPT	-			0 - 8.5 bar	C	Non-Relieving	K		
						0 - 17 bar	D	Low temp.	L		

Note: Bold options are most popular

Port size	Series	Description	Order code	Max bar	Height mm	Width mm	Depth mm
G1/2	PR10	BSPP - Standard knob	PR10G04CSS	20.7	126	62	60
G1/2	PR10	NPT - Standard knob	PR10-04CSS	20.7	126	62	60
G1/2	PR11	BSPP - Stainless steel tee handle	PR11G04CSS	20.7	154	62	60
G1/2	PR11	NPT - Stainless steel tee handle	PR11-04CSS	20.7	154	62	60

§ dm³/s = 7 bar inlet pressure with 5.5 bar set pressure and 1 bar pressure drop.

Warning

Product rupture can cause serious injury.
Do not connect regulator to bottled gas.
Do not exceed maximum primary pressure rating.

Specifications

Gauge port	G1/4	
Operation	Flourocarbon diaphragm	
Port threads	G1/2	
Operating temperature	PR10	-18°C to 66°C
	PR11	-18°C to 82°C
Option "L" minimum operating temperature	-40°C	
Max supply pressure	PR10	0 to 20.7 bar
	PR11	0 to 20.7 bar
Weight	810 g	

Note: Air must be dry enough to avoid ice formation at temperatures below 2°C.

Note: "Low Temperature" option is intended for applications where the ambient temperature may be down to -40° C/F. Air supply must be free of moisture to prevent ice formation and malfunction of units. These units contain EPDM seals. Make sure any oils in the airstream are compatible.

Materials of Construction

Adjustment mechanism / Springs	316 Stainless steel
Body	316 Stainless steel
Bonnet / Tee handle (PR11)	316 Stainless steel
Bonnet / Knob (PR10)	Acetal
Bottom plug	316 Stainless steel
Poppet	316 Stainless steel
Seals	Flourocarbon

Dimensions (mm)

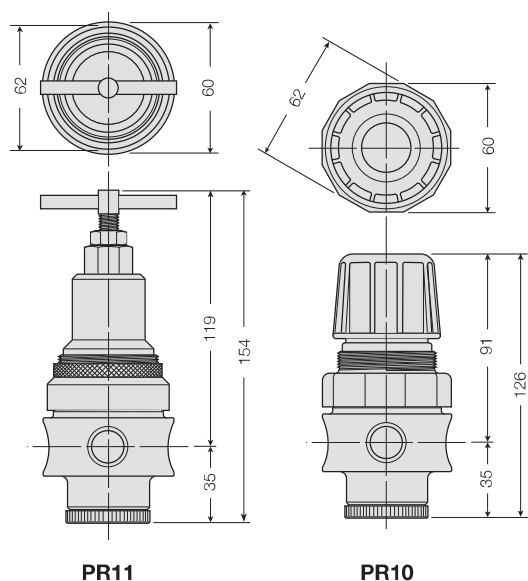

Note: 44mm dia. hole required for panel mounting.

Flow Charts

**Flow Characteristics - 1/2 Inch Ports
6.9 bar Primary Pressure**

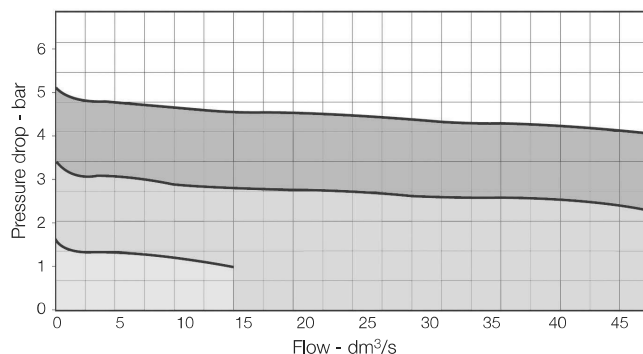

CAUTION:

REGULATOR PRESSURE ADJUSTMENT -

The working range of knob adjustment is designed to permit outlet pressures within their full range. Pressure adjustment beyond this range is also possible because the knob is not a limiting device. This is a common characteristic of most industrial regulators, and limiting devices may be obtained only by special design. For best performance, regulated pressure should always be set by increasing the pressure up to the desired setting.

Accessories

R10 Bonnet Kit	Knob included	CKR10YSS
R11 Bonnet Kit		CKR11YSS
Gauge - 0 to 10 bar	BSPP	M1/4G40S-10
	NPT	K4520N14160SS
Panel Mount Bracket (Stainless)		R10Y57-SS
Panel Mount Nut	Stainless	R10X51SS
	Plastic	R10X51-P
Pipe Nipple	1/2" NPT 316 Stainless Steel	616A28-SS
	1/2" BSPT 316 Stainless Steel	AC-4SS
Service Kit	Relieving	RKR10YSS
	Non-Relieving	RKR10KYSS

Operation

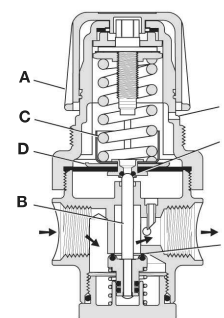

With the adjusting knob (A) turned fully counter-clockwise (no spring load), and pressure supplied to the regulator inlet port, the valve poppet assembly (B) is closed. Turning the adjusting knob clockwise applies a load to control spring (C). This load causes the diaphragm (D) and the valve poppet assembly (B) to move downward allowing flow across the seat area (E) created between the poppet assembly and the seat. Pressure in the downstream line is sensed below the diaphragm (D) and offsets the load of spring (C). As downstream pressure rises, poppet assembly (B) and diaphragm (D) move upward until the area (E) is closed and the load of the spring (C) and pressure under diaphragm (D) are in balance. A reduced outlet pressure has now been obtained, depending on spring load. Creating a demand downstream, such as opening a valve, results in a reduced pressure under the diaphragm (D). The load of control spring (C) now causes the poppet assembly to move downward opening seat area (E) allowing air to flow to meet the downstream demand. The flow of downstream air is metered by the amount of opening (E).

Should downstream pressure exceed the desired regulated pressure, the excess pressure will cause the diaphragm (D) to move upward against control spring (C), open vent hole (F), and vent the excess pressure to atmosphere through the hole in the bonnet (H). (This occurs in the relieving type regulator only.)