

Compressed Air Dryers

Balston Compressed Air Dryers

Balston offers both membrane and PSA technology. Balston Membrane Air Dryers combine superior coalescing technology with a proven, innovative membrane system to supply clean, dry compressed air with dewpoints as low as -40°F (-40°C).

Balston PSA Compressed Air Dryers will reduce the dewpoint of compressed air to -100°F (-73°C). Each dryer is delivered complete and ready for easy installation.



Product Features:

- Unattended 24 hour operation
- Compact
- Membrane and PSA technologies available
- Silent operation
- No desiccant to change
- Easy to install and operate

Moisture Sensitive Point of Use Areas



Main Ring Applications



Process and Production Equipment



Compressed Air Dryers

Membrane Air Dryers



Balston
Membrane Air Dryers

State-of-the-Art Membrane Technology

Water vapor from the compressed air supply passes through the hollow fibers of the membrane. At the same time, a small portion of the dry air product is redirected along the length of the fibers to sweep out the water vapor laden air which has permeated the membrane. The moisture-laden sweep gas is then vented to the atmosphere, and clean, dry air is supplied to the application. The drying power of the membrane is controlled by varying the compressed air flow rate and pressure. The Balston Membrane Air Dryer is designed to operate continuously, 24 hours per day, 7 days per week. The only maintenance required is changing the prefilter cartridge twice a year. This semi-annual maintenance takes approximately 5 minutes.

Offer a reliable, efficient, and economical alternative to pressure swing and refrigerant dryer technologies

Require no electricity thus lowering operating costs

Dewpoints as low as -40°F (-40°C) prevent freeze-ups

Explosion proof

Silent operation

No desiccant to change

Membrane Air Dryers

Balston Membrane Air Dryers combine a superior coalescing technology with a proven, innovative membrane system to supply clean, dry compressed air with dewpoints as low as -40°F (-40°C). The Membrane Air Dryers are engineered for easy installation, operation, and long term reliability. The dryers incorporate high efficiency coalescing filtration and the highest efficiency membrane available to provide low cost operation and minimal maintenance.

Applications

Low dewpoint instrument air	Prevention of freeze-ups
Pneumatic equipment	Dry air for hazardous areas
Pressurizing electronic cabinets	General laboratory air supply
Analytical instrumentation	Protect electrical panel components from moisture damage
Instrument air for analyzer buildings	

- "We have not had one shutdown due to freeze-ups since the Balston Membrane Dryer was installed."

Peter Vogt
International Filler Corp.

Compressed Air Dryers

Membrane Air Dryer - Principle of Operation

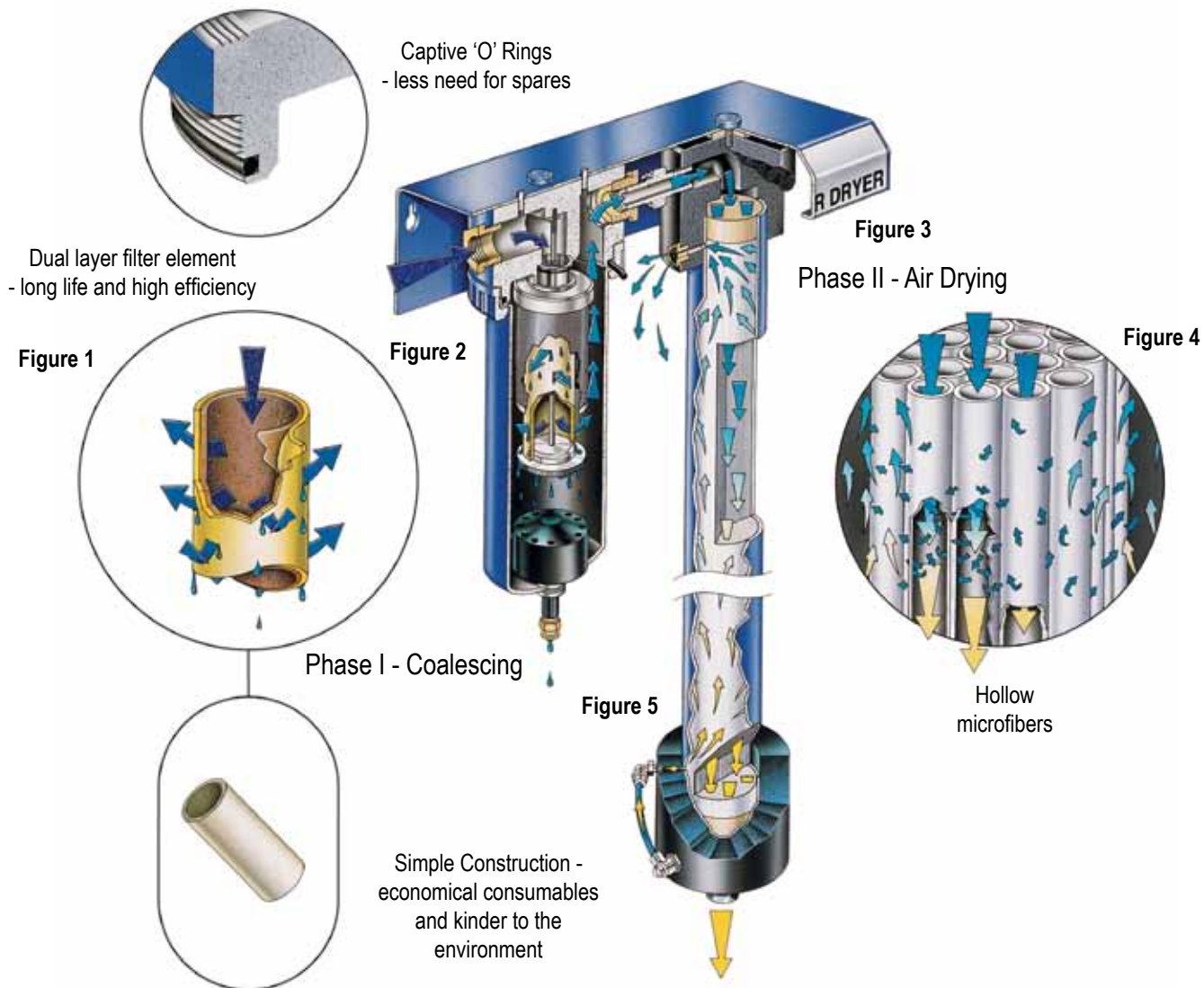

Phase I - Coalescing Filtration

Prior to entering the membrane drying module, the compressed air passes through a high efficiency coalescing filter to remove oil and water droplets and particulate contamination with an efficiency of 99.99% at 0.01 micron. The liquids removed by the filter cartridge continuously drip from the filter cartridge into the bottom of the housing, where they are automatically emptied by an aut drain assembly (see Fig. 1 and Fig. 2). The air leaving the prefilter, therefore, is laden only with water vapor, which will be removed in the membrane module.

Phase II - Drying

The water vapor in the compressed air is removed by the principle of selective permeation through a membrane (see Fig. 3). The membrane module consists of bundles of hollow membrane fibers (see Fig. 4), each permeable only to water vapor. As the compressed air passes through the center of these fibers, water vapor permeates through the walls of the fiber, and dry air exits from the other end of the fiber. A small portion of the dry air (regeneration flow) is redirected along the length of the membrane fiber to carry away the moisture-laden air which surrounds the membrane fibers. The remainder of the dry air is piped to the application.

Compressed Air Dryers

Membrane Air Dryers for -40°F (-40°C) Dewpoint



Model 76-01



Model 76-02



Model 76-10



Model 76-20



Model 76-40

Flow Rates		Outlet Flow in SCFM (Nm ³ /hr.) at Indicated Operating Pressure for -40°F (-40°C) Atmospheric Dewpoint				
Pressure Dewpoint	60 psig (4.1 BAR) -40°F(-40°C)	80 psig (5.5 BAR) -40°F(-40°C)	100 psig (6.9 BAR) -40°F(-40°C)	120 psig (8.3 BAR) -40°F(-40°C)	140 psig (7.7 BAR) -40°F(-40°C)	
Model 76-01	.3 (.5)	.6 (1)	1 (1.7)	1.3 (2.2)	1.7 (2.9)	
Model 76-02	.6 (1)	1 (1.7)	2 (3.4)	2.4 (4.1)	3.4 (5.8)	
Model 76-10	3.0 (5)	5 (8.5)	10 (17)	13 (22)	17 (29)	
Model 76-20	6.0 (10)	10 (17)	20 (34)	26 (44)	34 (58)	
Model 76-40	12.0 (20)	20 (34)	40 (68)	52 (88)	68 (116)	

Membrane Module Regeneration Flow		Regeneration Flow in SCFM (Nm ³ /hr.) at Indicated Operating Pressure and all dewpoints				
Pressure Dewpoint	60 psig (4.1 BARG)	80 psig 5.5 (BARG)	100 psig (6.9 BARG)	120 psig (8.3 BARG)	140 psig (7.7 BARG)	
Model 76-01	.2 (.34)	.2 (.34)	.3 (.5)	.3 (.5)	.3 (.5)	
Model 76-02	.34 (.58)	.4 (.68)	.5 (.84)	.6 (1)	.7 (1.2)	
Model 76-10	1.7 (2.9)	2.1 (3.6)	2.5 (4.2)	3 (5)	3.3 (5.6)	
Model 76-20	3.4 (5.8)	4.2 (7.1)	5 (8.5)	6 (10)	6.6 (11.2)	
Model 76-40	6.8 (11.6)	8.4 (14.3)	10 (17)	12 (20)	14 (23.8)	

Compressed Air Dryers

Membrane Air Dryers for -40°F (-40°C) Dewpoint

Principal Specifications

Model	76-01	76-02	76-10	76-20	76-40
Nominal Flow Rate At -40°F (-40°C) Dewpoint (1)	1 SCFM (1.7 Nm ³ /Hr)(1)	2 SCFM (3.4 Nm ³ /Hr)(1)	10 SCFM (1.7 Nm ³ /Hr)(1)	20 SCFM (3.4 Nm ³ /Hr)(1)	40 SCFM (6.8 Nm ³ /Hr)(1)
Min/Max Inlet Air Temp.	40°F/120°F (4°C/49°C) (2) →				
Ambient Temp. Range	40°F - 120°F (4°C - 49°C) →				
Min/Max Inlet Pressure	60 psig (4.1 barg)/150 psig (10.3 barg) →				
Compressed Air Requirement	Total Air Consumption: Regeneration Flow + Outlet Flow Requirements (see tables on pg.166)				
Max. Pressure Drop	5 psid (.34 barg) (3)	5 psid (.34 barg) (3)	5 psid (.34 barg) (3)	5 psid (.34 barg) (3)	5 psid (.34 barg) (3)
Wall Mountable	Yes	Yes	Yes	Yes	Yes
Prefilter (included)	Yes (4)	Yes (4)	Yes (4)	Yes (4)	Yes (4)
Inlet/Outlet Port Size	1/4" NPT (female)	1/4" NPT (female)	1/2" NPT (female)	1" NPT (female)	1 1/2" NPT (female)/ 3/4" NPT (female)
Electrical Requirements	None	None	None	None	None
Dimensions	6"W x 22"H x 5"D (15cm x 58cm x 13cm)	6"W x 23"H x 5"D (15cm x 58cm x 13cm)	6"W x 37"H x 5"D (15cm x 94cm x 13cm)	12"W x 37"H x 7"D (30cm x 94cm x 18cm)	19"W x 39"H x 8"D (48cm x 99cm x 21cm)
Shipping Weight	9 lbs. (4 kg)	10 lbs. (5 kg)	18 lbs. (9 kg)	20 lbs. (9 kg)	35 lbs. (16 kg)

Notes:

1 Dewpoint specified for saturated inlet air at 100°F (38°C) and 100 psig (6.9 barg). Outlet flows will vary slightly for other inlet conditions.

2 Inlet compressed air dewpoint must not exceed the ambient air temperature.

3 5 psid (.34 barg) at -40°F (-40°C) dewpoint operating parameters.

4 If compressed air is extremely contaminated, a Balston Grade DX prefilter should be installed directly upstream from the membrane dryer.

5 Filtration efficiency: 99.99% at 0.01 micron.

Ordering Information

For Assistance, call toll-free at 1-800-343-4048 8AM to 5PM Eastern Time

Description	Model Number				
Balston Membrane Air Dryer	76-01	76-02	76-10	76-20	76-40
Replacement Prefilter Cartridges	100-12-BX	100-12-BX	100-18-BX	150-19-BX	200-35-BX
Optional Additional Coalescing Prefilter	2002N-1B1-DX	2002N-1B1-DX	2104N-1B1-DX	2208N-1B1-DX	2312N-1B1-DX
Replacement Filter Cartridges for Optional Prefilter	100-12-DX	100-12-DX	100-18-DX	150-19-DX	200-35-DX
Pressure Regulator (0-130 psig) 1/2" NPT Ports	72-130	72-130	72-130	-----	---

Compressed Air Dryers

IT Series Membrane Air Dryers for +35°F (+2°C) Dewpoint*

Offer a reliable, efficient, and economical alternative to pressure swing and refrigerant dryer technologies

Require no electricity thus lowering operating costs

Produce +35°F (+2°C) dewpoint, ideal for critical points of use

Produce +15°F (-9°C) dewpoint in air systems with existing refrigerated air dryers

No moving parts

Silent operation

No desiccant to change



Applications

Food processing and automation

Electronics/Dry Boxes

Coordinate Measurement Machines

Critical Pneumatic Valves

Protection of Pneumatic Instrumentation

Low Dewpoint Instrument Air

Pneumatic Equipment

Dry Air for Hazardous Areas

IT Series Membrane Dryers

There are many variables that will affect the output specification of compressed air. By the time air reaches all its intended point of use, changes in pressure and temperature can contribute to potential contamination. As capital equipment tolerances become tighter and more sensitive to this contamination, maintenance costs will escalate if equipment is not adequately protected. In cases where standard air filtration is not sufficient or where the reliability, performance and operating cost of older dryer technologies is becoming more significant, a Balston Membrane Dryer provides a reliable and economical alternative.

IT Series Point of Use Membrane Dryers

Balston Membrane Air Dryers combine superior coalescing filtration technology with a proven, innovative membrane system to supply clean, dry, +35°F (+2°C) dewpoint compressed air. If the house compressed air is equipped with a refrigerated dryer, the dewpoint drops to +15°F (-9°C). The Balston Membrane Dryers are available in 8 different models which can deliver compressed air at flow rates up to 100 SCFM (170 NM³/Hr).

The systems are engineered for easy installation, operation, and long term reliability. By incorporating high efficiency coalescing filtration and the highest efficiency membrane available, the systems provide low cost operation with the lowest minimal maintenance.

* If the house compressed air is equipped with a refrigerated dryer, the dewpoint drops to +15°F (-9°C).

Compressed Air Dryers

IT Series Membrane Air Dryers for +35°F (+2°C) Dewpoint*

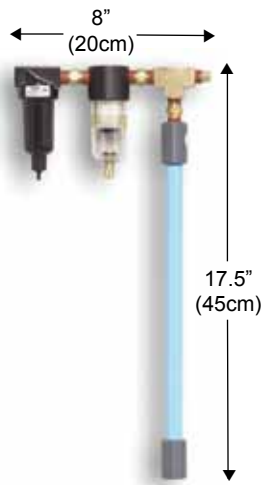

IT0010-35



IT0030-35



IT0080-35

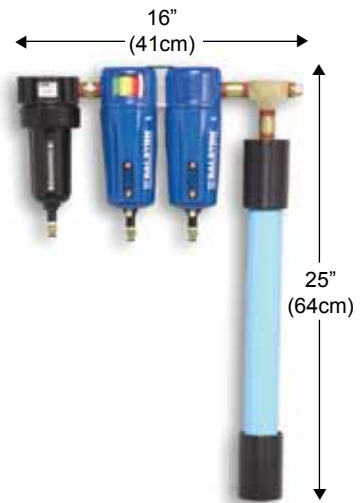

IT0150-35



IT0250-35XX



IT0500-35XX

Easy to Operate and Maintain

Installation consists of simply connecting a standard compressed air line to the inlet and connecting the outlet to your application. The unit is ready for trouble-free operation. This system is designed to operate 24 hours per day, 7 days per week.

Once the system is operating, it requires little monitoring. The only maintenance involves changing the coalescing prefilter cartridges periodically. The membrane module does not require any maintenance.

Flow Rates

Model Number	IT0010-35	IT0030-35	IT0080-35	IT0150-35	IT0250-3560	IT0250-3500	IT0500-3560	IT0500-3500	IT1000-3560	IT1000-3500
Flow @ 100 psig Inlet Pressure, scfm (Nm ³ /Hr)	1 (1.7)	3 (5.1)	8 (13.6)	15 (25.5)	25 (42.5)	N/A	50 (85)	N/A	100 (170)	N/A
Flow @ 101-150 psig Inlet Pressure, scfm (Nm ³ /Hr)	1 (1.7)	3 (5.1)	8 (13.6)	15 (25.5)	N/A	25 (42.5)	N/A	50 (85)	N/A	100 (170)
Regeneration Flow @ 100 psig, scfm (Nm ³ /Hr) (1)	0.25 (.42)	0.5 (.85)	1.5 (2.5)	2.7 (4.6)	4.5 (7.6)	4.5 (7.6)	9.0 (15.3)	9.0 (15.3)	18.0 (30.6)	18.0 (30.6)

(1) Total Air Consumption = Regeneration + Outlet Flow.

* If the house compressed air is equipped with a refrigerated dryer, the outlet dewpoint drops to +15°F (-9°C).

Compressed Air Dryers

IT Series Membrane Air Dryers for +35°F (+2°C) Dewpoint*

Principal Specifications

Model Number	IT0010-35	IT0030-35	IT0080-35	IT0150-35	IT0250-3560	IT0250-3500	IT0500-3560	IT0500-3500	IT1000-3560	IT1000-3500
Min/Max Inlet Air Temp.	40°F/120°F (4°C/49°C)	40°F/120°F (4°C/49°C)	40°F/120°F (4°C/49°C)	40°F/120°F (4°C/49°C)	40°F/120°F (4°C/49°C)	40°F/120°F (4°C/49°C)	40°F/120°F (4°C/49°C)	40°F/120°F (4°C/49°C)	40°F/120°F (4°C/49°C)	40°F/120°F (4°C/49°C)
Min/Max Ambient Air Temp.	40°F/120°F (4°C/49°C)	40°F/120°F (4°C/49°C)	40°F/120°F (4°C/49°C)	40°F/120°F (4°C/49°C)	40°F/120°F (4°C/49°C)	40°F/120°F (4°C/49°C)	40°F/120°F (4°C/49°C)	40°F/120°F (4°C/49°C)	40°F/120°F (4°C/49°C)	40°F/120°F (4°C/49°C)
Min/Max Inlet Pressure	60/150 psig (4.1/10 barg)	60/150 psig (4.1/10 barg)	60/150 psig (4.1/10 barg)	60/150 psig (4.1/10 barg)	60/100 psig (4.1/6.9 barg)	100/150 psig (6.9/10 barg)	60/100 psig (4.1/6.9 barg)	100/150 psig (6.9/10 barg)	100/150 psig (6.9/10 barg)	100/150 psig (6.9/10 barg)
Max. Pressure Drop (1)	3 psid (.2 bard)	3 psid (.2 bard)	3 psid (.2 bard)	3 psid (.2 bard)	5 psid (.34 bard)	5 psid (.34 bard)	5 psid (.34 bard)	5 psid (.34 bard)	5 psid (.34 bard)	5 psid (.34 bard)
Wall Mountable	Yes	Yes	Yes	Yes	Yes	Yes	Yes	Yes	Yes	Yes
Mechanical Separator (Included)	F14F17B	F06F18B	F06F18B	F07F38B	F07F38B	F07F38B	F07F38B	F07F38B	F602-08WJR	F602-08WJR
Coalescing Prefilters (1)	8A02N-OB2-BX	2002N-OB1-BX	2002N-OB1-BX	2004N-1B1-DX 2004N-OB1-BX	2104-1B1-DX 2104-OB1-BX	2104N-1B1-DX 2104-OB1-BX	2208N-1B1-DX 2208N-OB1-BX	2208N-1B1-DX 2208N-OB1-BX	2208N-1B1-DX 2208N-OB1-BX	2208N-1B1-DX 2208N-OB1-BX
inlet Port Size	1/4" NPT	1/4" NPT	1/4" NPT	1/2" NPT	1/2" NPT	1/2" NPT	1/2" NPT	1/2" NPT	1" NPT	1" NPT
Outlet Port Size	1/4" NPT	1/4" NPT	1/4" NPT	1/2" NPT	1" NPT	1" NPT	1" NPT	1" NPT	1" NPT	1" NPT
Electrical Requirements	None	None	None	None	None	None	None	None	None	None
Dimensions (cm)	17.5"Lx8"Wx2.5"D (44.5 x 20.3 x 6.3)	18.1"Lx10"Wx4"D (45.2 x 10.5 x 6.3)	24"Lx11.1"Wx4"D (61 x 28.2 x 6.3)	25"Lx16"Wx4.5"D (63.5 x 40.6 x 11.4)	26"Lx18"Wx6"D (66 x 45.7 x 15.2)	26"Lx18"Wx6"D (66 x 45.7 x 15.2)	39"Lx21"Wx6"D (99 x 53.3 x 15.2)	39"Dx21"Wx6"D (99 x 53.3 x 15.2)	47"Dx28"Wx7"D (119 x 71 x 18)	47"Dx28"Wx7"D (119 x 71 x 18)
Shipping Weight	1.62 lbs (.73 kg)	6.68 lbs (3 kg)	6.68 lbs (3 kg)	14.88 lbs (6.75 kg)	24.5 lbs (11.11 kg)	24.5 lbs (11.11 kg)	36.5 lbs (16.55 kg)	36.5 lbs (16.55 kg)	52 lbs (24 kg)	52 lbs (24 kg)

Notes:

- 1 If compressed air is extremely contaminated, a Grade DX prefilter should be installed directly upstream of the membrane dryer.
- 2 Filtration efficiency: 99.99% at 0.01 micron.

Ordering Information for assistance call toll free at 800-343-4048, 8AM to 5PM EST

Model Number	IT0010-35	IT0030-35	IT0080-35	IT0150-35	IT0250-3560	IT0250-3500	IT0500-3560	IT0500-3500	IT1000-3560	IT1000-3500
Replacement Prefilter Cartridges*										
Stage 1	PS403	PS702	PS702	PS802	PS802	PS802	PS802	PS802	EK602VB	EK602VB
Stage 2 **	---	---	---	5/100-12-DX	5/100-18-DX	5/100-18-DX	5/100-19-DX	5/150-19-DX	5/150-19-DX	5/150-19-DX
Stage 3	5/050-05-BX	5/100-12-BX	5/100-12-BX	5/100-12-BX	5/100-18-BX	5/100-18-BX	5/150-19-BX	5/150-19-BX	5/150-19-BX	5/150-19-BX

* If the house compressed air is equipped with a refrigerated dryer, the dewpoint drops to +15°F (-9°C).

Compressed Air Dryers

Membrane Air Dryers for Coordinate Measurement Machines

The Only Way To Remove Oil and Dry Compressed Air!

Now there is only one sensible way to remove oil and dry compressed air! Refrigerant air dryers are becoming a thing of the past. High efficiency, durable membrane technology is quickly becoming the standard for drying compressed air. Parker Hannifin is leading the way with membrane technology that consumes the least amount of compressed air for regeneration.

Balston CMM Air Dryers combine a superior coalescing technology with a proven, innovative membrane system to supply clean, dry compressed air with a constant dewpoint to 35°F (2°C). The Balston CMM Air Dryers are available in 2 different models which can deliver dry, compressed air at flow rates up to 15 SCFM (25.5 Nm³/Hr). The Balston Dryers are engineered for easy installation, operation, and long term reliability.



Customer Testimonial:

“Before we bought a Balston Membrane Dryer, we required two repairs to our CMM; the first cost \$10,000 and the next was over \$6,000. In the more than two years since installing the Balston Membrane Dryer we have not needed any repairs.”

Rick Nisula
Maintenance Buyer
Smith's Aerospace

Product Features:

- **Designed specifically for use with CMMs**
- **Protects CMMs from costly repairs caused by oil and water**
- **Ideal for supplying pure, dry air to Brown & Sharpe, Zeiss, IMS and MTI CMMs**
- **No heat or vibration generated; prevents inaccurate measurements**
- **Guaranteed dewpoint of 35°F (2°C)**
- **Requires no electricity resulting in lower operating costs**
- **Complete system with high efficiency coalescing filters**
- **Silent operation**
- **Minimal maintenance required**

Compressed Air Dryers

Membrane Air Dryers for Coordinate Measurement Machines

Problems that cause costly repairs to Coordinate Measurement Machines:

A CMM has 26 highly sensitive air bearings per machine. If oil and moisture are present in the air system supplying the air bearings, the .5mm hole in the bottom of the air bearing will become clogged producing a “drag” in the machine. As the resistance builds, it causes hysteresis in the measurements producing an inaccurate measurement.

If this problem is allowed to continue, the bearing will drag on the aluminum ways and wear a groove in the machine. Once a groove develops, the air bearing will not produce lift if air is leaking out through the groove in the machine ways. To correct the problem, a complete rebuild of the machine at the factory is necessary which can be as costly as purchasing a new machine.

If the problem is caught in time, a service team will be required to come to the facility to repair the machine. The team will remove the bearings and the holes and grooves are cleaned with alcohol. Each bearing is then resurfaced with 600-1500 grit paper. Badly corroded or pitted air bearings are replaced at a cost of \$200.00 per bearing. Air hoses are also replaced, and all air passages are cleaned. The machine is then reassembled, and the time-consuming and costly task of recalibrating the machine with the ball bar and a B89 test is performed as the final step in repairing the machine.

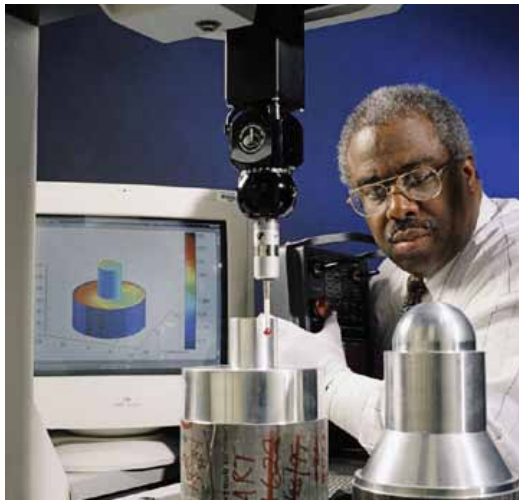

How to avoid costly maintenance problems:

Many repairs average upwards of \$5,000.00. These costly repairs and downtime can easily be avoided by installing a Balston high efficiency Membrane Air Dryer. The Balston Membrane Air Dryer will provide extremely clean, dry air to a CMM, eliminating the possibility of contamination. The Dryer utilizes patented membrane technology, unsurpassed in performance and durability to dehydrate and purify the compressed air. The Balston Membrane Dryer is the only system designed specifically for CMM applications.

Principal Specifications 35°F (2°C) Pressure Dewpoint (1)

Model Number	CM0080-35	CM0150-35
Flow @ 100 psig Inlet Pressure	8 scfm (13.6 Nm ³ /Hr)	15 scfm (25.5 Nm ³ /Hr)
Compressed Air Requirements	9.5 scfm (16.1 Nm ³ /Hr)	17.7 scfm (30 Nm ³ /Hr)
Min/Max Inlet Air Temp.	40°F/120°F (4°C/49°C)	40°F/120°F (4°C/49°C)
Min/Max Ambient Air Temp.	40°F/120°F (4°C/49°C)	40°F/120°F (4°C/49°C)
Min/Max Inlet Pressure	60/150 psig (4.1/10 barg)	60/150 psig (4.1/10 barg)
Max. Pressure Drop	3 psid (.2 bard)	3 psid (.2 bard)
Wall Mountable	Yes	Yes
Mechanical Separator Included	F06F18B	F07F38B
Coalescing Prefilters	8002N-0A1-BX	8004N-1A1-DX 8004N-0A1-BX
inlet Port Size	1/4" NPT	1/2" NPT
Outlet Port Size	1/4" NPT	1/2" NPT
Electrical Requirements	None	None
Dimensions (cm)	24"L x 11.1"W x 4"D (61cm x 28.2cm x 6.3cm)	25"L x 16"W x 4.5"D (63.5cm x 40.6cm x 11.4cm)
Shipping Weight	6.68 lbs (3 kg)	14.88 lbs (6.75 kg)

Notes:

- 1 Dewpoint specified for saturated inlet air at 100°F (38°C) and 100 psig.
- 2 Filtration efficiency: 99.99% at 0.01 micron.

Ordering Information

For assistance call toll free at 800-343-4048, 8AM to 5PM EST

Model Number	CM0080-35	CM0150-35
Replacement Filter Elements		
1st Stage	PS702	PS802
2nd Stage	100-12-BX	100-12-DX
3rd Stage	---	100-12-BX

Compressed Air Dryers

5000 Series Smart Dryer Membrane Air Dryers

Operating costs are 35 - 40% less than a refrigerant air dryer*

No electricity required

State-of-the-art membrane technology

Guaranteed 35°F (-2°C) dewpoint - 13% dryer than refrigerant dryers

Guaranteed 15°F (-9°C) in air systems equipped with a refrigerant air dryer

Durable - will hold up to the dirtiest compressed air system

No requirement for costly maintenance contracts

Output capacities to 200 scfm (340Nm³/Hr) **

Complete system with prefilters, autodrains, and pressure indicators



Model SMRT 5100

The Only Way To Dry Compressed Air!

Now, there is only one sensible way to dry compressed air! High efficiency, durable membrane technology is quickly becoming the standard for drying compressed air. Parker Hannifin is leading the way with membrane technology that consumes the least amount of compressed air for drying.

The SMART Dryer™ utilizes sophisticated technology to monitor system parameters and automatically adjusts the regenerative sweep flow as required. The variable sweep system results in significant energy savings and low operating costs.

The SMART Dryer™ technology offers another advantage over refrigerant air drying technology as it does not produce condensate. An average 25 HP compressor system can produce up to 1,800 gallons (6.8 m³) of oily condensate per year! The refrigerant dryer condenses it into an oily/water emulsion which has to be disposed of at a high cost to you! The Balston® Membrane Air Dryer is designed to operate continuously, 24 hours a day, 7 days a week. The only maintenance required is changing the prefilter cartridges twice a year, which take approximately 5 minutes and requires no tools!

*Non-cycling refrigerant air dryer

** Consult Factory for higher flow rates

Applications	Benefits
General Compressed Air Mainlines	Easy to install - no electrician required to install or maintain system
Process Controls	
HVAC Systems	
Instrument Cabinets	
CNC/CMM Machinery	
Fire and Sprinkler Systems	
Pneumatic Controls	
Dry Air for Hazardous Areas	
Chemical Blanketing and Packaging	
Electronics/Dry Boxes	
Laser Optics	
Spray Painting	
Bag House Controls	
	No refrigerants or freons - environmentally friendly
	Complete system with prefilters, auto drains, and pressure gauges
	Compact size

Compressed Air Dryers

5000 Series Smart Dryer Membrane Air Dryers

Why buy a Balston SMART Dryer™ instead of a cycling refrigerant air dryer?

The Balston SMART Dryer will save YOU money and offer better performance!

All Balston SMART Dryers require no electricity.

All air dryers are sized based on the maximum capacity output of a compressed air system with inlet conditions assumed to be 100°F inlet temperature, 100 psig inlet pressure and 100°F ambient temperature. In the majority of installations, it is unlikely air dryers will be required to operate under these extreme conditions. Most importantly, the majority of compressed air systems are not operating at the maximum output capacity.

Refrigerant and desiccant air dryers, sized to meet these operating conditions are designed to run continuously regardless of the system's demands, when in fact the actual system conditions are far less.

The result is significant operating costs in wasted energy and wear and tear on refrigerant compressors, cooling systems, drains and other componentry.

In a typical manufacturing plant operating one 8 hour shift with a 100 SCFM (170 Nm³/Hr) compressor system running at 75% capacity (on average over the 8 hour shift), a typical non-cycling refrigerant air dryer would cost \$716 in just electrical costs alone, compared to the Balston SMART Dryer with only \$436 in electrical costs. If you factor in the annual maintenance costs of \$600 for a non-cycling refrigerant dryer compared to \$130 for the Balston SMART Dryer, there is a total annual savings of over \$750.

Recently, refrigerant manufacturers have responded to this issue by developing a cycling air dryer which cools a cold storage heat sink reservoir. Once the reservoir is cooled to the minimum temperature the compressor (refrigerant) is shut off. The compressor cycles back on when the temperature of the storage reservoir reaches a preset upper limit. This reduces the total energy consumption of the dryer however it could produce significant variations in output dewpoints.

The Balston SMART Dryer does not require refrigerant, compressors, cooling systems or other componentry that carries high operating costs (energy) and maintenance costs. The Balston SMART Dryer utilizes sophisticated technology to monitor the system parameters and automatically adjusts the regenerative sweep flow as required. The variable sweep system results in significant energy savings and low operating costs with no fluctuation in output dewpoints.

In a typical manufacturing plant operating an 8 hour shift with a 100 SCFM (170 Nm³/Hr) compressor system

running at 75% capacity (on average over the 8 hour shift), a typical cycling refrigerant air dryer would cost \$454.00 in electrical costs alone, compared to the Balston SMART Dryer with only \$436.00 in electrical costs. If you factor in the annual maintenance cost of \$800 for a cycling refrigerant dryer compared to \$130.00 for the Balston SMART Dryer, there is a total annual savings of over \$685.00

Additionally, there are no moving parts, no freons that need recharging, no compressors to be serviced and no cooling coils to be cored and cleaned.

Most importantly, the Balston SMART Dryer is producing a constant 35°F dewpoint which is 13% dryer than a cycling refrigerant air dryer (ppm weight in air).

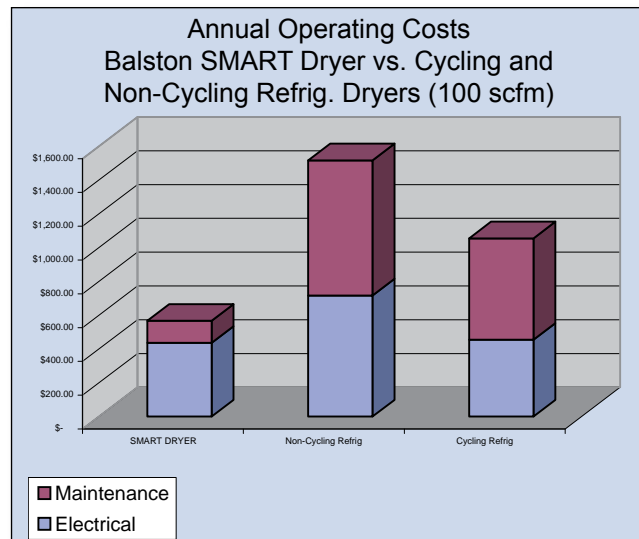

Here's What Our Customers Say

"Our compressed air system is now completely dry and clean at a very reasonable cost. And we gain at least three hours of production time each week by not having to shut down to clean rusted valves..."

Wayne Etchells, Vice President
Melton Corporation, Cranston, R.I.

"This new type of membrane dryer was just what we needed to eliminate problems with water building up in compressed air lines...Since the day we installed it, we haven't had a single problem with rust. The time and money we save by not having to repair spindles and air motors pays for the cost of the dryer every few months."

John Napier, Maintenance Engineer
King Machine, Akron, OH

Compressed Air Dryers

5000 Series Smart Dryer Membrane Air Dryers

Model SMRT5100
Front View

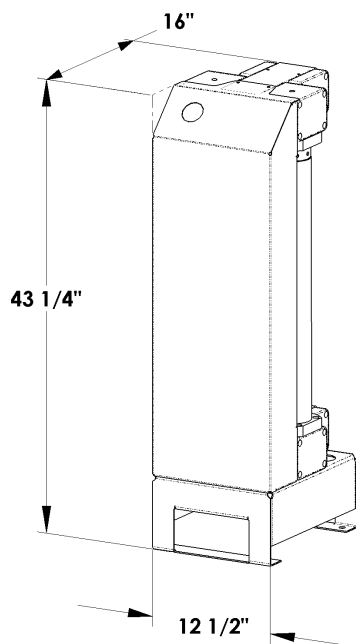

Model SMRT5200
Front View

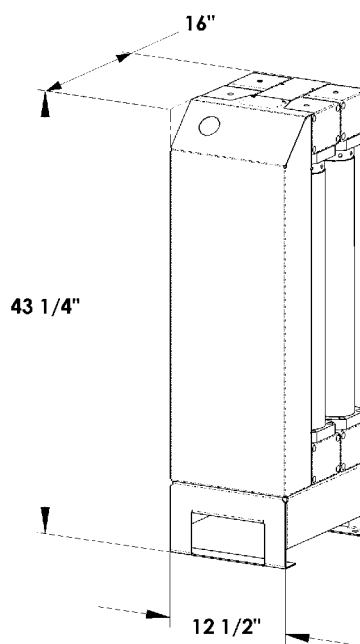

Principal Specifications

Model Number	Membrane Air Dryers SMRT5100	SMRT5200
Max Flow Rate @35°F(2°C) dewpoint	100 SCFM (170 Nm ³ /Hr)	200 SCFM (340 Nm ³ /Hr)
Dewpoint	35°F (2°C) / 15°F (-9°C) (1)	35°F (2°C) / 15°F (-9°C) (1)
Min/Max Inlet Air Temp.	40°F/120°F (4°C/49°C)	40°F/120°F (4°C/49°C)
Ambient Temp. Range	40°F/110°F (4°/43°C)	40°F/110°F (4°/43°C)
Min/Max Inlet Pressure	80 psig/150 psig (5.5 barg/10 barg)	80 psig/150 psig (5.5 barg/10 barg)
Max Inlet Dewpoint	120°F (49°C)	120°F (49°C)
Max Compressed Air Requirement	113 SCFM (192 Nm ³ /Hr)	226 SCFM (384 Nm ³ /Hr)
Max Pressure Drop	10 psid (0.7 bard) (2)	10 psid (0.7 bard) (2)
Inlet/Outlet Port Size	1 1/2"NPT(male)	2"NPT(male)
Physical Dimensions	12.5"w x 43.25"h x 16"d (3) (31.75cm x 109.9cm x 40.6cm)	12.5"w x 43.25"h x 16"d (3) (31.75cm x 109.9cm x 40.6cm)
Shipping Weight	175 lbs(86 kg)	250 lbs(113kg)

Notes:

- 1 35°F (2°C) Dewpoint specified for saturated inlet air at 100°F(38°C) and max. flow at 100 psig (6.9 barg). 15°F (-9°C) Dewpoint specified for saturated inlet air at 50°F (10°C) and max. flow at 100 psig (6.9 barg).
- 2 Max. pressure drop measured at max flow rate @ 100 psig (6.9 barg). Pressure drop will increase at lower feed pressures - consult factory.
- 3 Excluding coalescing prefilter assembly.
- 4 Filtration efficiency: 99.99% at 0.01 micron.

Ordering Information For assistance call 1-800-343-4048

Model Number	SMRT5100	SMRT5200
Coalescing Prefilter Assembly	2312N-1B1-DX 2312N-1B1-BX	A15/80-DX A15/80-BX
Replacement Prefilter Cartridges (every 6 months)	200-35-DX 200-35-BX	200-80-DX 200-80-BX
Membrane Replacement Module	D01-0086	D01-0086
Automatic Drain Kit	21552	21552

Compressed Air Dryers

Cabinet Dryers Eliminate Moisture Problems in Electrical Cabinets and Motors

Balston CD Series Cabinet Dryers

You demand a lot from your electrical cabinets and motors. They are subject to nightly high pressure, hot wash downs and then expected to remain dry in a refrigerated area. Over time most cabinets develop moisture inside which leads to premature component failures. This interrupts production and costs you money. Expensive vortex coolers or heaters don't work. Vortex coolers use a considerable amount of air and have a high operating cost. Heaters simply raise the humidity of the air inside the cabinet and don't eliminate the moisture.

The Parker Balston Cabinet Dryer serves to reduce the humidity inside the cabinet to less than 10% RH. Any water that infiltrates the cabinet evaporates quickly. Electrical components stay clean and dry which prolongs their life.

Avoid costly down time!

Many plants struggle with moisture problems by managing downtime emergencies. Emergencies divert limited maintenance personnel and disrupt production at the cost of thousands of dollars per hour. The Cabinet Dryer reduces these maintenance and lost production costs by 80% or more. A typical customer will see savings of \$10K - 15K per year. The Cabinet Dryer will operate continuously and reliably without operator attention thus freeing up valuable maintenance personnel who are better devoted to important routine maintenance work rather than daily emergency response.

Product Features:

- Designed specifically for wash down areas
- Protects electrical cabinet components from damage caused by water and high humidity
- Minimizes pools of water inside cabinets
- Positive pressure keeps dust out
- Adds no heat to the cabinet
- Reduces cabinet humidity to less than 10% RH
- Requires no electricity, low operating costs
- Easy to install and maintain
- Quiet operation
- Protect motors, touch screens, drives and other critical components



Do Your Cabinets Look Like This?



Corrosion leads to premature component failure

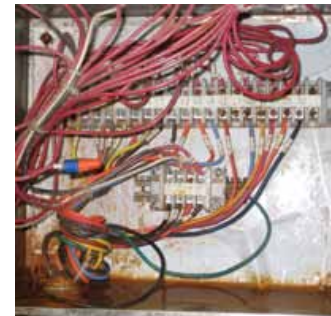

Water accumulation in electrical cabinet

A Cabinet Dryer will keep your cabinets looking as good as new



Compressed Air Dryers

Cabinet Dryers Eliminate Moisture Problems in Electrical Cabinets and Motors

Principal Specifications

Model Number	CD0005	CD0010	CD0030
Cabinet Size Range (2)	0 - 4 FT ³ (0 - 0.11m ³)	4 - 12 FT ³ (0.11m ³ - 0.34m ³)	12 - 36 FT ³ (0.34m ³ - 1m ³)
Min/Max Inlet Air Temp	40°F/120°F (4°C/49°C)	40°F/120°F (4°C/49°C)	40°F/120°F (4°C/49°C)
Min/Max Ambient Air Temp	35°F/120°F (2°C/49°C)	35°F/120°F (2°C/49°C)	35°F/120°F (2°C/49°C)
Air Consumption	0.6 SCFM (17 slpm)	1.25 SCFM (35.4 slpm)	3.5 SCFM (99 slpm)
Min/Max Air Pressure	60 psi/150 psi (4.1 BAR/10.3 BAR)	60 psi/150 psi (4.1 BAR/10.3 BAR)	60 psi/150 psi (4.1 BAR/10.3 BAR)
Delivered Dew Point	-7°F(-22°C) (1)	-7°F(-22°C) (1)	-7°F(-22°C) (1)
Inlet and Outlet Port Size	1/4" NPT	1/4" NPT	1/4" NPT
Electrical Requirements	None	None	None
Dimensions	3"w x 9.2"h x 2"d (7.6cm x 2.34cm x 5cm)	3"w x 15.2"h x 2"d (7.6cm x 38.6cm x 5cm)	4.6"w x 15.3"h x 2.9"d (11.7cm x 38.9cm x 7.4cm)
Shipping Weight	1.5 lbs (0.68 kg)	2 lbs (0.9 kg)	2.5 lbs (1.1 kg)

Notes:

1 Delivered dewpoint is specified for saturated inlet air at 100°F (38°C) and 100 psig (6.9 BAR).

2 If the cabinet is not tightly sealed, consider upsizing to the next module size.

3 Filtration efficiency: 99.99% at 0.01micron.

4 For heavily contaminated air lines, install additional prefiltration.

Ordering Information For assistance call toll free at 800-343-4048, 8AM to 5PM EST

Model Number	CD0005	CD0010	CD0030
Replacement Filter Elements	070-063-BX	070-063-BX	070-063-BX
Replacement Auto Drain	C02-2392	C02-2392	C02-2392

Here's what our customers say:

"We tried heaters, fans and vortex coolers, our only solution was to use a Parker Balston dryer that continuously purges the cabinet with dry air."

- Lee Clarkson
Ross Industries

"I've been with Smithfield for 15 years and we've had issues with wet electrical cabinets for 15 years. We installed the cabinet dryer on our wet-test cabinet to see if it would work. Our Multivac™ packager was having significant issues. It was out of service 2-3 times per week due to condensation inside the cabinet. When we installed the dryer we noticed a difference right away. The water droplets on the walls of the cabinet were gone and our downtime from moisture was completely eliminated. It worked just like they told me."

Maintenance Manager
Large Meat Processing Plant



Compressed Air Dryers

PSA Air Dryer



Balston
Compressed Air
Dryer

Reduce the dewpoint of compressed air to -100°F (-73°C)

Unattended 24 hour operation

Lightweight and compact

No desiccant to change

Applications

Pneumatic Tool Stations
HVAC Systems
Purge Electrical Boxes
Air Lines Subject to Sub-Freezing Temperatures
Blanketing Moisture Sensitive Materials
Spray Painting
Pneumatic Instrumentation
Robotics
Lasers
Dry Boxes

Model 75-A20NA

Balston regenerative PSA desiccant dryer reduces the atmospheric dewpoint of compressed air without operator attention. Model 75-A20NA will reduce the dewpoint to -100°F (-73°C). The dryer is delivered complete and ready for easy installation. The dryer has coalescing prefilters with automatic drains, PSA drying towers, a particulate final filter, a moisture indicator, differential pressure indicator, and pretested controls.

The Balston regenerative dryer has safe, 12 VDC electrical controls. To install, simply attach the inlet (60 psig/4.1 BARG minimum) and outlet air lines, plug the electrical transformer into a wall outlet - no electrician required - and the unit is ready for trouble-free operation.

This reliable dryer can be easily installed, operated, and maintained by personnel not trained in instrumentation. The Balston dryer is useful when air comes into contact with moisture-sensitive materials, or when outside compressed air lines are subjected to sub-freezing temperatures.

The 75-A20NA is a wall mountable unit. It has a 10 SCFM/min. (283 lpm) capacity (at 100 psig/6.9 BARG inlet pressure).

Compressed Air Dryers

PSA Air Dryer

Principal Specifications

Model	75-A20NA
Dewpoint	-100°F (-73°C) (1)
Max. Dry (outlet) Air Flow Rate for Specified Dew Point (1)	
Inlet Pressure 125 psig	12.0 SCFM (340 lpm)
Inlet Pressure 100 psig	10.0 SCFM (283 lpm)
Inlet Pressure 80 psig	8.3 SCFM (235 lpm)
Inlet Pressure 60 psig	6.5 SCFM (184 lpm)
Air Loss for Regeneration	2.5 SCFM (71 lpm) (2)
Min/Max Inlet Air Pressure	60 psig/125 psig (4.1 BARG/8.6 BARG)
Max. Inlet Air Temperature	78°F (25°C) (3)
Pressure Drop at Max. Flow Rate	8 psid (0.055 BARD)
Inlet/Outlet Port Size (female)	1/4" NPT
Electrical Requirements	120 VAC/60 Hz. (4)
Shipping Weight	50 lbs. (23 kg)
Dimensions	15"W X 41"H (38cm X 104cm)

Notes:

1 Dewpoint will be lower than specified at lower air flow.

2 Total air required = air loss for regeneration + process demand (up to max. dry air flow rate).

3 Outlet dewpoint will increase at higher inlet compressed air temperatures.

4 Power consumption - less than 10 watts. Each dryer is shipped with a 12 VDC plug-in transformer to connect to the local electrical supply.

5 Filtration efficiency: 99.99% at 0.01 micron.

Ordering Information

For Assistance, call toll-free at 1-800-343-4048 8AM to 5PM Eastern Time

Description	Model Number
Balston Compressed Air Dryer	75-A20NA
Replacement Filter Cartridges 1st stage (box of 10)	100-18-DX
Replacement Filter Cartridges 2nd stage (box of 10)	100-18-BX
Maintenance Kit, 1 year supply of filter cartridges	MK7525P

Customer Support and Service Network for Balston® Products



Customer Support and Assistance

Balston products are supported by a staff of 70+ highly trained sales and service specialists located throughout North America and Canada.

The Specialists are continuously trained and updated on all Balston branded products and technologies, ensuring prompt, accurate customer service.

When on-site service isn't practical, replacement items are shipped the same day you contact us directly to your facility from one of our near by Stocking Centers or directly from our Manufacturing Plant. We guarantee overnight delivery and we pay the freight!

World Class Manufacturing

All Balston branded products are manufactured within strict guidelines of a total quality management program. Each product incorporates superior workmanship and the best quality components available ensuring long term reliability and trouble free operation. Your complete satisfaction is guaranteed.

Technical Support Staff

If you have technical questions, special product modifications or unique applications, Balston's technical information and support staff are available to assist you with your requirements.

These highly trained application engineers are committed to ensuring your questions are answered accurately, and your special needs are attended to. In addition, they will work closely with you on new and unique applications.

This team of engineers can be contacted at 1-800-343-4048 8AM to 5PM Eastern Time.