

Butterfly Valves

In these robust valves, the internal component used to shut off the flow is a segment of a sphere. This allows **frequent operation with very low torque, no fluid retention areas** and therefore excellent mechanical performance.

Product Advantages

Compact & Abrasion-Resistant

- Excellent with abrasive fluids (including solid particles)
- Fluid flow direction marked for greater safety (uni-directional)
- Smooth operation
- Can be easily adapted for use with auxiliary actuators
- More compact than a ball valve with equivalent nominal diameter
- Simple and efficient design for a long service life

- Painting & Printing
- Machine Tools
- Pneumatics
- Powder Conveyance
- Plumbing
- Rubber Industry
- Petrochemical

Applications

Technical Characteristics

Compatible Fluids	Compressed air, industrial gases, water, cutting oils, hydraulic oils, fuel oil, fuel, etc.
Working Pressure	0 to 16 bar
Working Temperature	-20°C to +80°C

Reliable performance is dependent upon the type of fluid conveyed.

Component Materials

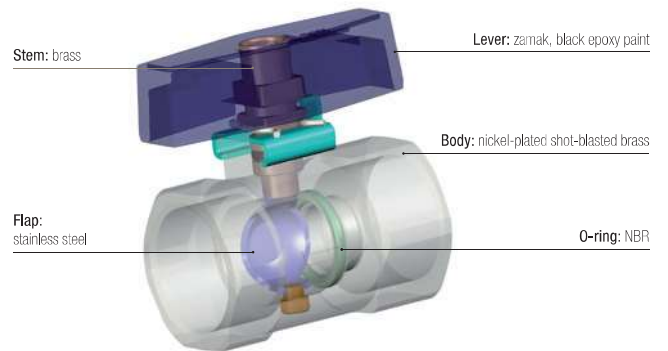

Silicone-free

Regulations

- DI:** 97/23/EC (module PED A - diameters greater than 25 mm)
- DI:** 2006/42/EC (Machinery Directive)
- DI:** 2002/95/EC (RoHS)
- RG:** 1907/2006 (REACH)

Butterfly Valves

4602

2/2 Butterfly Shut-Off Valve, Female BSPP Thread

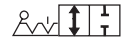

Nickel-plated brass, NBR

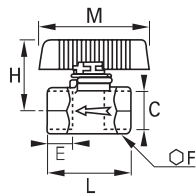

C	DN		E	F	H	L	M	kg
G1/4	6	4602 06 13	9	17	35	34	54	0.098
G3/8	7	4602 07 17	11	22	35	39	54	0.136
G1/2	10	4602 10 21	12	24	37	42	54	0.140
G3/4	13	4602 13 27	14	30	40	49	54	0.208
G1	18	4602 18 34	15	41	46	55	54	0.412

Black epoxy-coated zamak handle