

# ▶ MK-DS SERIES DIGITAL SCROLL INTEGRATED FILTRATION



# COMPRESSED AIR DRYERS ◀

Each and every compressed air user around the world has been looking for a complete solution to associate the best practices of energy management with their refrigerated air dryers, not just to protect the environment, but also to save money on operating costs.

Mikropor is proud to announce that the new MK-DS series explicitly prevails over any other type of refrigerated air dryer by achieving everyone's goal to lower energy costs.

The MK-DS Series, with a specially designed heat exchanger and digital scroll compressor, provides unrivalled energy efficiency in a refrigerated air dryer.

The challenge of maintaining a stable dewpoint and saving energy can be overcome with this latest technological development.

Combining Mikropor's expertly designed heat exchanger, leading filtration technology and digital scroll compression in Mikropor's MK-DS dryers provides the ultimate energy efficiency solution for compressed air systems with varying levels of air demand.



Energy Comparison

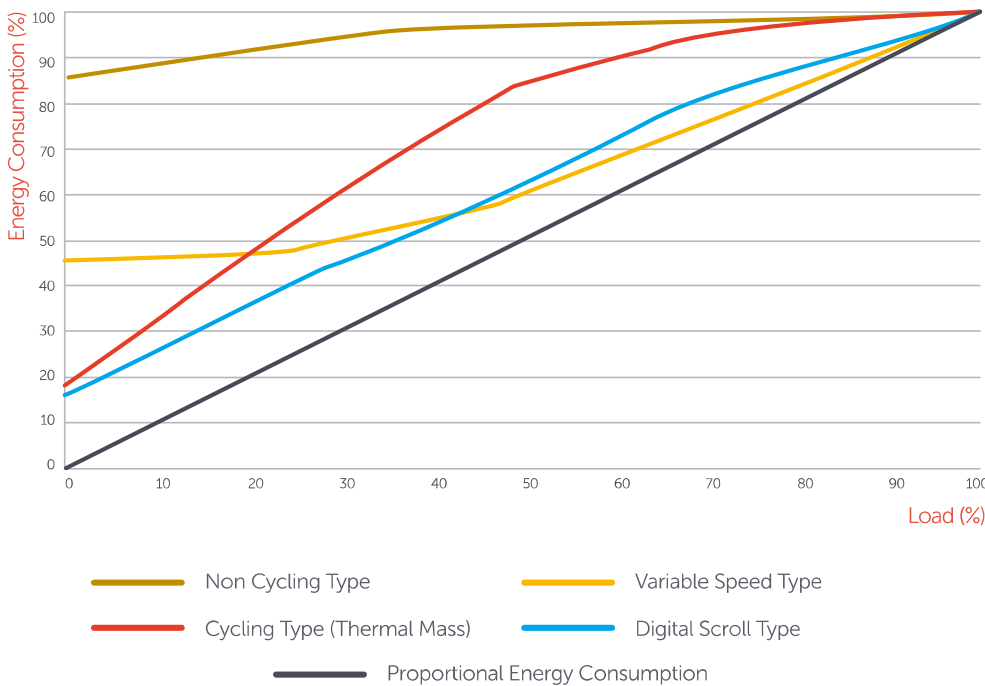

## ▶ MK-DS SERIES DIGITAL SCROLL INTEGRATED FILTRATION

## COMPRESSED AIR DRYERS ◀

- **Best in Class** energy saving
- Refrigeration systems are designed with digital scroll compressors and have an automatic switch to control loaded and unloaded states according to real-time air load demand during system operation in order to maximize energy savings.
- Advanced and user friendly electronic control system
- Electronic expansion valve
- Fan speed control
- Integrated filters
- Low pressure drop
- Energy efficiency is maximized through the design of the exclusive aluminium plate type heat exchangers.
- The advanced digital scroll compression technology not only improves efficiency, durability and reliability but also lowers the decibel sound levels compared to a standard refrigerated air dryer.
- Environmentally friendly low-pressure R-134a refrigerant gas is used in digital scroll compressor to pressurize the system.
- The smart control unit named kW-DS Controller provides high energy efficiency with electricity consumption optimized for variable capacities.



**kW Saver**



STABILITY



PERFORMANCE

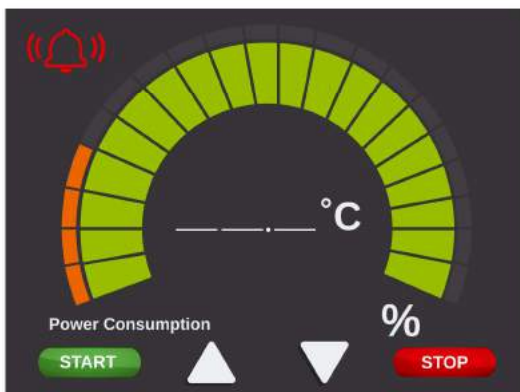

The advanced digital scroll technology utilized in Mikropor's MK-DS Series dryers maintains a stable pressure dew point while performing **up to 91% energy savings** during operation.

### How It Works?

Unlike most refrigerated dryers in the industry, Mikopor's MK-DS series utilize a proprietary digital evaporator technology to deliver significant energy savings over traditional cycling and variable speed designs.

This brand new technological breakthrough offers a vital opportunity to save the highest amount of energy possible in a refrigerated air dryer. The digital compressor operates with various different ranges of inlet flow conditions which also makes it by far the most energy efficient compressor to be utilized in a refrigerated air dryer.

MK-DS Dryers are equipped with a true no-loss condensate drain which provides effective condensate removal without any loss of (valuable) compressed air.

Maximum energy savings are achieved by establishing continuous communication with the temperature probe in the evaporator which adjusts the refrigeration pressure to the temperature of the air exiting the evaporator.

### Fundamental Components of the MK-DS Series

- Digital Scroll Compressor
- Electronic Expansion Valve
- Variable Speed Fan Motor
- Highly Engineered Control Algorithm
- Cutting-Edge Technology Electronic Controller

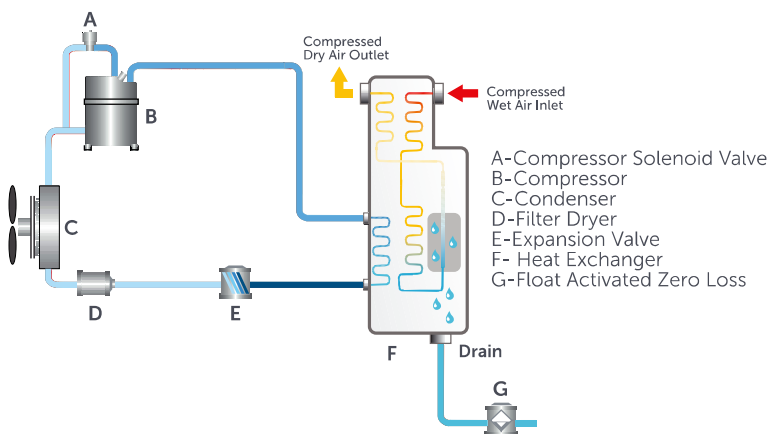

Mikopor's latest MK-DS series refrigerated dryer technology saves the highest amount of energy possible on the market.

### Why is MK-DS so energy efficient and cost effective ?

Non-cycling refrigerated dryers are designed to run continuously and consume almost 100% of the nominal power at all loads. Hence, it makes no difference if a facility is operational or not - A non-cycling dryer will just keep running, regardless of the air demand at any given time. As mentioned above, digital scroll technology equipped dryers can be loaded or unloaded automatically depending upon the real-time air load demand and this feature simply makes the MK-DS range much more energy efficient than any other type of refrigerated air dryer.

With the energy savings calculation tool, the users can compare how much energy can be saved for different dryer selections.

ENERGY SAVING CALCULATION			
Energy Unit Price	0,06	€/kWh	
Daily Working Hours	24	hour	
Monthly Working Days	30	day	
SELECTED AIR DRYER MODELS			
	<b>DIGITAL SCROLL AIR DRYER MK-DS 260</b>	<b>VS</b>	<b>STANDARD AIR DRYER MKE 12500</b>
Monthly Ener. Consumption	<b>6882 kWh</b>		<b>13417 kWh</b>
<b>Total Power Savings</b>	<b>Total Power Savings Annual</b>	<b>Total Cost Saved Annual</b>	
<b>49%</b>	<b>78415 kWh</b>	<b>€ 4.705</b>	

### Energy Saving Example

Consider a 12500 Nm<sup>3</sup>/h non-cycling refrigerated air dryer running continuously for 720 hours monthly at an average energy cost of €0.06 per kWh.

In this scenario the non-cycling air dryer will consume 13417 kWh of electricity.

An equivalent MK-DS air dryer, rated at 12500 Nm<sup>3</sup>/h operating at the same conditions over the same period, would consume 6882 kWh.

Consequently the MK-DS air dryer will achieve energy savings of € 4.705 compared to a non-cycling air dryer per annum.

### MK-DS Series - Technical Specifications

Model	Capacity (m <sup>3</sup> /h)	Voltage	Connection Size	Filter Quantity and Type	Replacement Filter Element Kit	Control Type
MK-DS-120	930	400V / 3 Ph / 50 Hz	2"	1*GKON1205X + 1*GKON1205Y	MKON1205 KIT	µPc
MK-DS-130	1200	400V / 3 Ph / 50 Hz	2"	1*GKON1205X + 1*GKON1205Y	MKON1205 KIT	µPc
MK-DS-140	1388	400V / 3 Ph / 50 Hz	3"	1*GKON-HC-1805X + 1*GKON-HC-1805Y	MKON-HC-1805 KIT	µPc
MK-DS-150	1800	400V / 3 Ph / 50 Hz	3"	1*GKON-HC-1805X + 1*GKON-HC-1805Y	MKON-HC-1805 KIT	µPc
MK-DS-170	2775	400V / 3 Ph / 50 Hz	3"	1*GKON-HC-2775X + 1*GKON-HC-2775Y	MKON-HC-2775 KIT	µPc
MK-DS-180	3330	400V / 3 Ph / 50 Hz	DN100 Flange	1*GKO5850X + 1*GKO5850Y	GKO5850 KIT	µPc
MK-DS-190	3915	400V / 3 Ph / 50 Hz	DN100 Flange	1*GKO5850X + 1*GKO5850Y	GKO5850 KIT	µPc
MK-DS-200	5085	400V / 3 Ph / 50 Hz	DN100 Flange	1*GKO5850X + 1*GKO5850Y	GKO5850 KIT	µPc
MK-DS-210	5850	400V / 3 Ph / 50 Hz	DN100 Flange	1*GKO5850X + 1*GKO5850Y	GKO5850 KIT	µPc
MK-DS-220	6975	400V / 3 Ph / 50 Hz	DN150 Flange	** Externally Connected - F6500 X / Y	6*M1200 KIT	µPc
MK-DS-230	7875	400V / 3 Ph / 50 Hz	DN150 Flange	** Externally Connected - F8500 X / Y	8*M1200 KIT	µPc
MK-DS-240	9000	400V / 3 Ph / 50 Hz	DN150 Flange	** Externally Connected - F11000 X / Y	10*M1200 KIT	µPc
MK-DS-250	10500	400V / 3 Ph / 50 Hz	DN200 Flange	** Externally Connected - F11000 X / Y	10*M1200 KIT	µPc
MK-DS-260	12500	400V / 3 Ph / 50 Hz	DN200 Flange	** Externally Connected - F14000 X / Y	14*M1200 KIT	µPc

Nominal Working Pressure	7 barg
Maximum Working Pressure	16 barg
Minimum Working Pressure	4 barg
Nominal Inlet Temperature	35°C
Maximum Inlet Temperature	50°C

Minimum Inlet Temperature	5°C
Nominal Ambient Temperature	25°C
Maximum Ambient Temperature	45°C
Minimum Ambient Temperature	5°C
Refrigerant	R134a