

## Suction Strainer (Polyamide End Cap) Type SUS

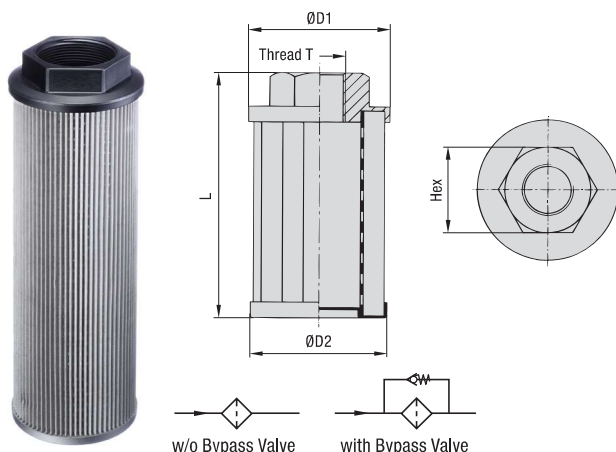

### Flow Characteristics

#### Nominal Flow Rate vs. Pressure Drop $\Delta P$

The following characteristics are valid for Mineral oils with a mass density of 0,85 kg/dm<sup>3</sup> and a kinematic viscosity of 30 mm<sup>2</sup>/s (cSt) at +38 °C / +100 °F.

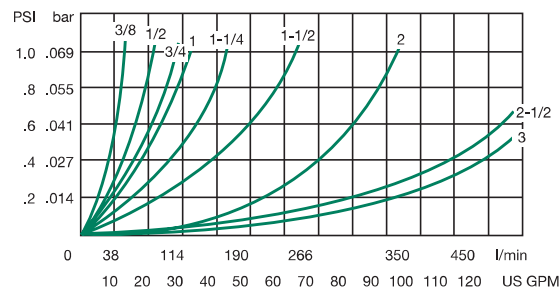

### Characteristics

Designed as in-tank suction strainer elements for direct installation into suction lines of pumps; should always be installed below the minimum fluid level of the reservoir

#### Features

- Available with female BSP thread (ISO 228) or female NPT thread (ANSI B1.20.1)
- Operating temperature range: -20 °C ... +100 °C / -4 °F ... +212 °F

#### Media Compatibility

- Suitable for use with Mineral and Petroleum based hydraulic fluids (HL and HLP)

#### Materials

- Threaded end cap made of glass-fibre reinforced Polyamide (PA); see page 51 for version with Aluminium end cap
- Lower end cap and support tube made of Steel, zinc-plated
- Standard filter material is Stainless Steel Mesh (125 µm); alternative micron ratings of 60 µm and 250 µm on request

#### Options

- Integrated bypass valve with an opening pressure of 0,2 bar (3 PSI) to reduce the risks of high-pressure drops that can be caused by contaminated strainer elements or high-viscosity fluids

Special sizes, designs, materials and configurations are available on request. Contact STAUFF for details.

Contact STAUFF for alternative materials.

### Dimensions and Technical Data (Female BSP Threaded Version)

Group Size	Thread T	Dimensions (mm/in)				Filter Surface	Max. Flow Rate
		ØD1	ØD2	L	Hex		
040-G06-075	G3/8 BSP	39,5	38,5	75	22	279 cm <sup>2</sup>	12 l/min
		1,56	1,53	2,93	.87	43 in <sup>2</sup>	3,1 US GPM
050-G06-067	G3/8 BSP	50	49	67	26	296 cm <sup>2</sup>	12 l/min
		1,97	1,93	2,64	1,02	46 in <sup>2</sup>	3,1 US GPM
050-G08-105	G1/2 BSP	50	49	105	26	518 cm <sup>2</sup>	15 l/min
		1,97	1,93	4,13	1,02	80 in <sup>2</sup>	3,9 US GPM
068-G12-105	G3/4 BSP	68	66	105	34	676 cm <sup>2</sup>	25 l/min
		2,68	2,60	4,13	1,34	105 in <sup>2</sup>	6,5 US GPM
068-G16-140	G1 BSP	68	66	140	42	930 cm <sup>2</sup>	50 l/min
		2,68	2,60	5,51	1,65	144 in <sup>2</sup>	13,0 US GPM
088-G20-140	G1-1/4 BSP	88	85	140	50	1172 cm <sup>2</sup>	65 l/min
		3,46	3,35	5,51	1,97	182 in <sup>2</sup>	16,9 US GPM
088-G24-140	G1-1/2 BSP	88	85	140	60	1172 cm <sup>2</sup>	140 l/min
		3,46	3,35	5,51	2,36	182 in <sup>2</sup>	36,4 US GPM
102-G24-200	G1-1/2 BSP	102	100	200	72	2427 cm <sup>2</sup>	140 l/min
		4,02	3,94	7,87	2,83	376 in <sup>2</sup>	36,4 US GPM
102-G32-200	G2 BSP	102	100	200	72	2427 cm <sup>2</sup>	230 l/min
		4,02	3,94	7,87	2,83	376 in <sup>2</sup>	59,8 US GPM
102-G32-225	G2 BSP	102	100	225	72	2811 cm <sup>2</sup>	230 l/min
		4,02	3,94	8,86	2,83	436 in <sup>2</sup>	59,8 US GPM
102-G32-260	G2 BSP	102	100	260	72	3249 cm <sup>2</sup>	230 l/min
		4,02	3,94	10,24	2,83	504 in <sup>2</sup>	59,8 US GPM
102-G32-300	G2 BSP	102	100	300	72	3798 cm <sup>2</sup>	230 l/min
		4,02	3,94	11,81	2,83	589 in <sup>2</sup>	59,8 US GPM
131-G40-191	G2-1/2 BSP	131	128	191	86	2430 cm <sup>2</sup>	340 l/min
		5,16	5,04	10,24	3,39	377 in <sup>2</sup>	88,4 US GPM
131-G40-212	G2-1/2 BSP	131	128	212	86	2748 cm <sup>2</sup>	340 l/min
		5,16	5,04	8,35	3,39	426 in <sup>2</sup>	88,4 US GPM
131-G48-272	G3 BSP	131	128	272	96	3626 cm <sup>2</sup>	400 l/min
		5,16	5,04	10,71	3,78	562 in <sup>2</sup>	104 US GPM
150-G32-151	G2 BSP	150	145	151	70	1812 cm <sup>2</sup>	400 l/min
		5,91	5,71	5,94	2,76	281 in <sup>2</sup>	104 US GPM

### Dimensions and Technical Data (Female NPT Threaded Version)

Group Size	Thread T	Dimensions (mm/in)				Filter Surface	Max. Flow Rate
		ØD1	ØD2	L	Hex		
050-N06-067	3/8 NPT	50	49	67	26	296 cm <sup>2</sup>	12 l/min
		1,97	1,93	2,64	1,02	46 in <sup>2</sup>	3,1 US GPM
050-N06-090	3/8 NPT	50	49	90	26	430 cm <sup>2</sup>	12 l/min
		1,97	1,93	3,54	1,02	67 in <sup>2</sup>	3,1 US GPM
050-N08-105	1/2 NPT	50	49	105	26	518 cm <sup>2</sup>	15 l/min
		1,97	1,93	4,13	1,02	80 in <sup>2</sup>	3,9 US GPM
068-N12-105	3/4 NPT	68	66	105	34	676 cm <sup>2</sup>	25 l/min
		2,68	2,60	4,13	1,34	105 in <sup>2</sup>	6,5 US GPM
068-N16-140	1 NPT	68	66	140	42	930 cm <sup>2</sup>	50 l/min
		2,68	2,60	5,51	1,65	144 in <sup>2</sup>	13,0 US GPM
088-N20-140	1-1/4 NPT	88	85	140	50	1172 cm <sup>2</sup>	65 l/min
		3,46	3,35	5,51	1,97	182 in <sup>2</sup>	16,9 US GPM
088-N20-195	1-1/4 NPT	88	85	195	60	1709 cm <sup>2</sup>	65 l/min
		3,46	3,35	7,68	2,36	265 in <sup>2</sup>	16,9 US GPM
088-N24-140	1-1/2 NPT	88	85	140	60	1172 cm <sup>2</sup>	140 l/min
		3,46	3,35	5,51	2,36	182 in <sup>2</sup>	36,4 US GPM
088-N24-226	1-1/2 NPT	88	85	226	60	2012 cm <sup>2</sup>	140 l/min
		3,46	3,35	8,90	2,36	312 in <sup>2</sup>	36,4 US GPM
088-N24-260	1-1/2 NPT	88	85	260	60	2344 cm <sup>2</sup>	140 l/min
		3,46	3,35	10,24	2,36	363 in <sup>2</sup>	36,4 US GPM
102-N24-200	1-1/2 NPT	102	100	200	72	2427 cm <sup>2</sup>	140 l/min
		4,02	3,94	7,87	2,83	376 in <sup>2</sup>	36,4 US GPM
102-N32-260	2 NPT	102	100	260	72	3249 cm <sup>2</sup>	230 l/min
		4,02	3,94	10,24	2,83	504 in <sup>2</sup>	59,8 US GPM
131-N40-212	2-1/2 NPT	131	128	212	86	2748 cm <sup>2</sup>	340 l/min
		5,16	5,04	8,35	3,39	426 in <sup>2</sup>	88,4 US GPM
131-N48-272	3 NPT	131	128	272	96	3626 cm <sup>2</sup>	400 l/min
		5,16	5,04	10,71	3,78	562 in <sup>2</sup>	104 US GPM



## Suction Strainer (Aluminium End Cap) Type SUS

### Flow Characteristics

#### Nominal Flow Rate vs. Pressure Drop $\Delta P$

The following characteristics are valid for Mineral oils with a mass density of 0,85 kg/dm<sup>3</sup> and a kinematic viscosity of 30 mm<sup>2</sup>/s (cSt) at +38 °C / +100 °F.

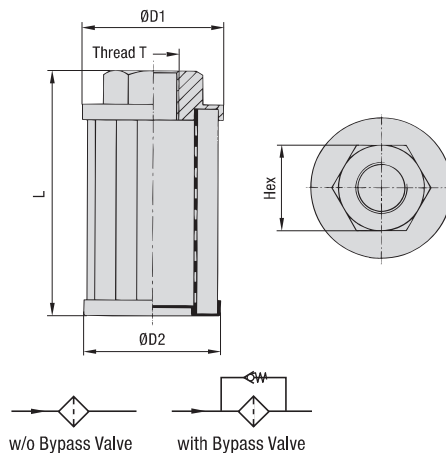
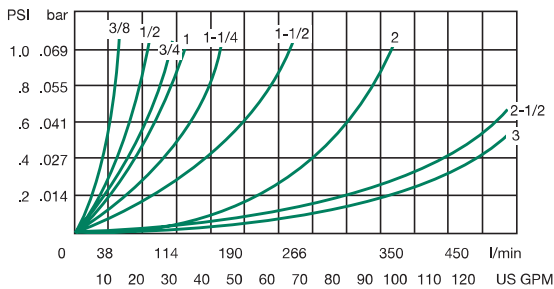

### Characteristics

Designed as in-tank suction strainer elements for direct installation into suction lines of pumps; should always be installed below the minimum fluid level of the reservoir

#### Features

- Available with female NPT thread (ANSI B1.20.1)
- Operating temperature range: -20 °C ... +100 °C / -4 °F ... +212 °F

#### Media Compatibility

- Suitable for use with Mineral and Petroleum based hydraulic fluids (HL and HLP)

#### Materials

- Threaded end cap made of Aluminium; see page 50 for version with Polyamide (PA) end cap
- Lower end cap and support tube made of Steel, zinc-plated
- Filter material made of Stainless Steel Mesh (125 µm); alternative micron ratings of 60 µm and 250 µm on request

Contact STAUFF for alternative materials.

#### Options

- Integrated bypass valve with an opening pressure of 0,2 bar (3 PSI) to reduce the risks of high-pressure drops that can be caused by contaminated strainer elements or high-viscosity fluids

Special sizes, designs, materials and configurations are available on request. Contact STAUFF for details.

### Dimensions and Technical Data (Female NPT Threaded Version)

Group Size	Thread T	Dimensions (mm/in)				Filter Surface	Max. Flow Rate
		ØD1	ØD2	L	Hex		
050-N06-067	3/8 NPT	50	49	67	26	296 cm <sup>2</sup>	12 l/min
		1.97	1.93	2.64	1.02	46 in <sup>2</sup>	3.1 US GPM
050-N06-090	3/8 NPT	50	49	90	26	430 cm <sup>2</sup>	12 l/min
		1.97	1.93	3.54	1.02	67 in <sup>2</sup>	3.1 US GPM
050-N08-105	1/2 NPT	50	49	105	26	518 cm <sup>2</sup>	15 l/min
		1.97	1.93	4.13	1.02	80 in <sup>2</sup>	3.9 US GPM
068-N12-105	3/4 NPT	68	66	105	34	676 cm <sup>2</sup>	25 l/min
		2.68	2.60	4.13	1.34	105 in <sup>2</sup>	6.5 US GPM
068-N16-140	1 NPT	68	66	140	42	930 cm <sup>2</sup>	50 l/min
		2.68	2.60	5.51	1.65	144 in <sup>2</sup>	13.0 US GPM
088-N20-140	1-1/4 NPT	88	85	140	50	1172 cm <sup>2</sup>	65 l/min
		3.46	3.35	5.51	1.97	182 in <sup>2</sup>	16.9 US GPM
088-N20-195	1-1/4 NPT	88	85	195	60	1709 cm <sup>2</sup>	65 l/min
		3.46	3.35	7.68	2.36	265 in <sup>2</sup>	16.9 US GPM
088-N24-140	1-1/2 NPT	88	85	140	60	1172 cm <sup>2</sup>	140 l/min
		3.46	3.35	5.51	2.36	182 in <sup>2</sup>	36.4 US GPM
088-N24-226	1-1/2 NPT	88	85	226	60	2012 cm <sup>2</sup>	140 l/min
		3.46	3.35	8.90	2.36	312 in <sup>2</sup>	36.4 US GPM
088-N24-260	1-1/2 NPT	88	85	260	60	2344 cm <sup>2</sup>	140 l/min
		3.46	3.35	10.24	2.36	363 in <sup>2</sup>	36.4 US GPM
088-N32-260	2 NPT	88	85	260	70	2344 cm <sup>2</sup>	230 l/min
		3.46	3.35	10.24	2.76	363 in <sup>2</sup>	59.8 US GPM
150-N40-213	2-1/2 NPT	150	145	213	90	2741 cm <sup>2</sup>	340 l/min
		5.91	5.71	8.39	3.54	425 in <sup>2</sup>	88.4 US GPM
150-N48-272	3 NPT	150	145	272	100	3625 cm <sup>2</sup>	400 l/min
		5.91	5.71	10.71	3.94	562 in <sup>2</sup>	104 US GPM

### Order Codes

**SUS - 088-G24-140 - 125 - P - O**

① Type: Suction Strainer for direct installation into suction lines of pumps **SUS**

② Group Size: Select 'Group Size' from corresponding column in dimensional tables

The group size is defined by the diameter ØD1 of the threaded end cap, the thread code (type and size) and the total length of the suction strainer element (e.g. 040-B06F-075).

③ Filter Material / Micron Rating

Stainless Steel Mesh, 125 µm (standard option)	<b>125</b>
Stainless Steel Mesh, 60 µm	<b>060</b>
Stainless Steel Mesh, 250 µm	<b>250</b>

Contact STAUFF for alternative materials / micron ratings.

④ Material of Threaded End Cap

Glass-fibre reinforced Polyamide	<b>P</b>
Aluminium (for female NPT threaded version only)	<b>A</b>

⑤ Bypass Option

Without bypass valve (standard option)	<b>0</b>
Integrated bypass valve with opening pressure of 0,2 bar (3 PSI)	<b>B0.2</b>

