



# Modular Type Regulators *Series AR*

Regulator Series AR	Model	Port size	Options
 <p data-bbox="167 958 496 992">Pages 346 through to 355</p>	<b>AR10</b>	M5 x 0.8	
	<b>AR20</b>	1/8, 1/4	
	<b>AR25</b>	1/4, 3/8	
	<b>AR30</b>	1/4, 3/8	
	<b>AR40</b>	1/4, 3/8, 1/2	
	<b>AR40-06</b>	3/4	
	<b>AR50</b>	3/4, 1	
	<b>AR60</b>	1	
 <p data-bbox="167 1384 496 1417">Pages 346 through to 355</p>	<b>AR20K</b>	1/8, 1/4	Bracket Square embedded type pressure gauge (except the AR10) Round type pressure gauge Digital pressure switch (except the AR10) Panel mount
	<b>AR25K</b>	1/4, 3/8	
	<b>AR30K</b>	1/4, 3/8	
	<b>AR40K</b>	1/4, 3/8, 1/2	
	<b>AR40K-06</b>	3/4	
	<b>AR50K</b>	3/4, 1	
	<b>AR60K</b>	1	

AC

AF□

**AR**

AL

AW□

A□G

AV

AF800  
AF900

# Regulator

# AR10 to AR60

## Regulator with Backflow Function

# AR20K to AR60K

JIS Symbol  
Regulator

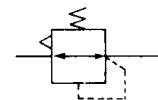

Regulator with  
Backflow Function

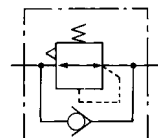

- With the backflow function it incorporates a mechanism to exhaust the air pressure in the outlet side reliably and quickly.

Example 1)

When the pressure in the rear and the front of the cylinder differs:

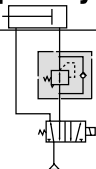

Example 2)

When the air supply is cut off and releasing the inlet pressure to the atmosphere, the residual pressure release of the outlet side can be ensured for a safety purpose.

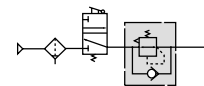

## How to Order

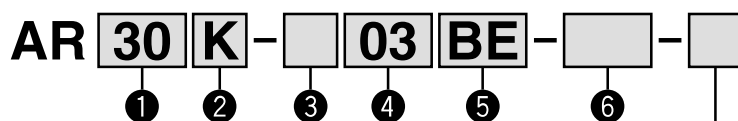

Made to Order

(Refer to pages 354 and 355 for details.)

- Option/Semi-standard: Select one each for a to g.
- Option/Semi-standard symbol: When more than one specification is required, indicate in alphanumeric order.  
Example) AR30K-03BE-1NR

		Symbol	Description	① Body size							
				10	20	25	30	40	50	60	
②	With backflow function	Nil	Without backflow function	●	●	●	●	●	●	●	
		K <small>Note 1)</small>	With backflow function	—	●	●	●	●	●	●	
+											
③	Thread type	Nil	Metric thread (M5)	●	—	—	—	—	—	—	
		N	Rc	—	●	●	●	●	●	●	
		F	NPT	—	●	●	●	●	●	●	
			G	—	●	●	●	●	●	●	
+											
④	Port size	M5	M5	●	—	—	—	—	—	—	
		01	1/8	—	●	—	—	—	—	—	
		02	1/4	—	●	●	●	●	—	—	
		03	3/8	—	—	●	●	●	—	—	
		04	1/2	—	—	—	—	●	—	—	
		06	3/4	—	—	—	—	●	●	—	
		10	1	—	—	—	—	—	●	●	
+											
⑤ <small>Note 2)</small> Option	a	Mounting	Nil	Without mounting option	●	●	●	●	●	●	●
			B <small>Note 3)</small>	With bracket	●	●	●	●	●	●	●
			H	With set nut (for panel fitting)	●	●	●	●	●	—	—
	+										
	b	Pressure gauge	Nil	Without pressure gauge	●	●	●	●	●	●	●
			E	Square embedded type pressure gauge (with limit indicator)	—	●	●	●	●	●	●
			G	Round type pressure gauge (without limit indicator)	●	—	—	—	—	—	—
			M	Round type pressure gauge (with limit indicator)	—	●	●	●	●	●	●
		Digital pressure switch	E1 <small>Note 4)</small>	Output: NPN output / Electrical entry: Wiring bottom entry	—	●	●	●	●	●	●
	E2 <small>Note 4)</small>	Output: NPN output / Electrical entry: Wiring top entry	—	●	●	●	●	●	●		
	E3 <small>Note 4)</small>	Output: PNP output / Electrical entry: Wiring bottom entry	—	●	●	●	●	●	●		
	E4 <small>Note 4)</small>	Output: PNP output / Electrical entry: Wiring top entry	—	●	●	●	●	●	●		

# Regulator *Series AR10 to AR60* Regulator with Backflow Function *Series AR20K to AR60K*



AR20, AR20K    AR40, AR40K

		Symbol	Description	①								
				Body size								
				10	20	25	30	40	50	60		
⑥	Semi-standard	c	Set pressure	Nil <sup>Note 5)</sup>	0.05 to 0.85 MPa setting							
				↑ <sup>Note 6)</sup>	0.02 to 0.2 MPa setting							
		+										
		d	Exhaust mechanism	Nil	Relieving type							
				N	Non-relieving type							
		+										
		e	Flow direction	Nil	Flow direction: Left to right							
				R	Flow direction: Right to left							
		+										
		f	Knob	Nil	Downward							
				Y	Upward							
		+										
g	Pressure unit	Nil	Name plate and pressure gauge in imperial units: MPa									
		Z <sup>Note 7)</sup>	Name plate and pressure gauge in imperial units: psi									
		ZA <sup>Note 8)</sup>	Digital pressure switch: With unit conversion function									
				○ <sup>Note 9)</sup>	○ <sup>Note 9)</sup>	○ <sup>Note 9)</sup>	○ <sup>Note 9)</sup>	○ <sup>Note 9)</sup>	○ <sup>Note 9)</sup>	○ <sup>Note 9)</sup>		
				—	△ <sup>Note 10)</sup>	△ <sup>Note 10)</sup>	△ <sup>Note 10)</sup>	△ <sup>Note 10)</sup>	△ <sup>Note 10)</sup>	△ <sup>Note 10)</sup>		

Note 1) The AR10 type comes with a backflow function as a standard feature. (K is not available.) When using the AR10 type as w/ backflow function, backflow may not occur with the set pressure 0.15 MPa or less. Please set the inlet pressure to at least 0.05 MPa higher than the set pressure.

Note 2) Option B, G, H, M are not assembled and supplied loose at the time of shipment.

Note 3) Assembly of a bracket and set nuts (AR10, AR20(K) to AR40(K))  
Including 2 mounting screws for the AR50(K) and AR60(K)

Note 4) When choosing with H (panel mount), the installation space for lead wires will not be secured. In this case, select "wiring top entry" for the electrical entry. (Select "wiring bottom entry" when the semi-standard Y is chosen simultaneously.)

Note 5) Only the AR10 has a pressure setting of 0.05 to 0.7 MPa.

Note 6) The only difference from the standard specifications is the adjusting spring for the regulator. It does not restrict the setting of 0.2 MPa or more. When the pressure gauge is attached, a 0.2 MPa pressure gauge will be fitted.

Note 7) For thread type: M5 and NPT. This product is for overseas use only according to the new Measurement Law. (The SI unit type is provided for use in Japan.)  
The digital pressure switch will be equipped with the unit conversion function, setting to psi initially.

Note 8) For options: E1, E2, E3, E4. This product is for overseas use only according to the new Measurement Law. (The SI unit is provided for use in Japan.)

Note 9) ○: For thread type: M5 and NPT only

Note 10) △: Select with options: E1, E2, E3, E4.

## Standard Specifications

Model	AR10	AR20(K)	AR25(K)	AR30(K)	AR40(K)	AR40(K)-06	AR50(K)	AR60(K)
Port size	M5 x 0.8	1/8, 1/4	1/4, 3/8	1/4, 3/8	1/4, 3/8, 1/2	3/4	3/4, 1	1
Pressure gauge port size <sup>Note 1)</sup>	1/16 <sup>Note 2)</sup>	1/8			1/4			
Fluid	Air							
Ambient and fluid temperature <sup>Note 3)</sup>	-5 to 60°C (with no freezing)							
Proof pressure	1.5 MPa							
Maximum operating pressure	1.0 MPa							
Set pressure range	0.05 to 0.7 MPa	0.05 to 0.85 MPa						
Relief pressure <sup>Note 4)</sup>	Set pressure + 0.05 MPa [at relief flow rate of 0.1 ℓ/min (ANR)]							
Construction	Relieving type							
Mass (kg)	0.06	0.26	0.21	0.29	0.44	0.47	1.17	1.22

Note 1) Pressure gauge connection threads are not available for F.R.L. unit with a square embedded type pressure gauge (AR20(K) to AR60(K)).

Note 2) Use a bushing (part no:131368) when connecting the R1/8 pressure gauge to the Rc1/16.

Note 3) -5 to 50°C for the products with the digital pressure switch.

Note 4) Not applicable to the AR10.

# Series AR10 to AR60

## Series AR20K to AR60K

### Options/Part No.

Option		Model	AR10	AR20(K)	AR25(K)	AR30(K)	AR40(K)	AR40(K)-06	AR50(K)	AR60(K)	
<b>Bracket assembly</b> <sup>Note 1)</sup>			AR10P-270AS	AR20P-270AS	AR25P-270AS	AR30P-270AS	AR40P-270AS		AR50P-270AS <sup>Note 2)</sup>		
<b>Set nut</b>			AR10P-260S	AR20P-260S	AR25P-260S	AR30P-260S	AR40P-260S		— <sup>Note 3)</sup>	— <sup>Note 3)</sup>	
<b>Pressure gauge</b>	<sup>Note 4)</sup> Round type	<b>Standard</b>	G27-10-R1		G36-10-□01		G46-10-□02				
		<b>0.02 to 0.2 MPa setting</b>	G27-10-R1 <sup>Note 5)</sup>		G36-2-□01		G46-2-□02				
	<sup>Note 4)</sup> Round type (with color zone)	<b>Standard</b>	—		G36-10-□01-L		G46-10-□02-L				
		<b>0.02 to 0.2 MPa setting</b>	—		G36-2-□01-L		G46-2-□02-L				
	<sup>Note 6)</sup> Square embedded type	<b>Standard</b>	—		GC3-10AS [GC3P-010AS (Pressure gauge cover only)]						
		<b>0.02 to 0.2 MPa setting</b>	—		GC3-2AS [GC3P-010AS (Pressure gauge cover only)]						
<b>Digital pressure switch</b>	NPN output: Wiring bottom entry		—	ISE35-N-25-MLA [ISE35-N-25-M (Switch body only)] <sup>Note 7)</sup>							
	NPN output: Wiring top entry			ISE35-R-25-MLA [ISE35-R-25-M (Switch body only)] <sup>Note 7)</sup>							
	PNP output: Wiring bottom entry			ISE35-N-65-MLA [ISE35-N-65-M (Switch body only)] <sup>Note 7)</sup>							
	PNP output: Wiring top entry			ISE35-R-65-MLA [ISE35-R-65-M (Switch body only)] <sup>Note 7)</sup>							

Note 1) Assembly of a bracket and set nuts

Note 2) Assembly of a bracket and 2 mounting screws

Note 3) Please consult with SMC regarding the set nuts for the AR50(K) and AR60(K).

Note 4) □ in part numbers for a round pressure gauge indicates a type of connection thread. No indication is necessary for R; however, indicate N for NPT. Please contact SMC regarding the connection thread NPT and pressure gauge supply for psi unit specifications.

Note 5) Pressure gauge for general purpose

Note 6) Including one O-ring and 2 mounting screws. [ ]: Pressure gauge cover only

Note 7) Lead wire with connector (2 m), adapter, lock pin, O-ring (1 pc.), mounting screw (2 pcs.) are attached. [ ]: Switch body only  
Also, regarding how to order the digital pressure switch, please refer to page 388.

## ⚠ Specific Product Precautions

**Be sure to read before handling. Refer to front matters 42 and 43 for Safety Instructions and pages 287 to 291 for F.R.L. Precautions.**

### Selection

#### ⚠ Warning

- Residual pressure disposal (outlet pressure removal) is not possible for the AR20 to AR60 even though the inlet pressure is exhausted. When the residual pressure disposal is performed, use the regulator with a backflow function (AR20K to AR60K).

### Maintenance

#### ⚠ Warning

- When using the regulator with backflow function between a solenoid valve and an actuator, check the pressure gauge periodically. Sudden pressure fluctuations may shorten the durability of the pressure gauge. A digital pressure gauge is recommended for such situation or as deemed necessary.

### Mounting and Adjustment

#### ⚠ Warning

- Set the regulator while verifying the displayed values of the inlet and outlet pressure gauges. Turning the regulator knob excessively can cause damage to the internal parts.
- The pressure gauge included with regulators for 0.02 to 0.2 MPa setting is for up to 0.2 MPa use only (except the AR10). Exceeding 0.2 MPa of pressure can damage the gauge.
- Do not use tools on the pressure regulator knob as this may cause damage. It must be operated manually.

#### ⚠ Caution

- Be sure to unlock the knob before adjusting the pressure and lock it after setting the pressure. Failure to follow this procedure can cause damage to the knob and the outlet pressure may fluctuate.
  - Pull the pressure regulator knob to unlock. (You can visually verify this with the "orange mark" that appears in the gap.)
  - Push the pressure regulator knob to lock. When the knob is not easily locked, turn it left and right a little and then push it (when the knob is locked, the "orange mark", i.e., the gap will disappear).

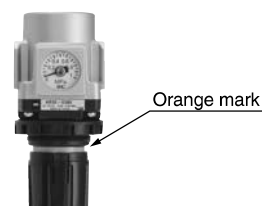

- A knob cover is available to prevent careless operation of the knob. Refer to page 389 for details.

# Regulator *Series AR10 to AR60* Regulator with Backflow Function *Series AR20K to AR60K*

## Flow Characteristics (Representative values)

Condition: Inlet pressure 0.7 MPa

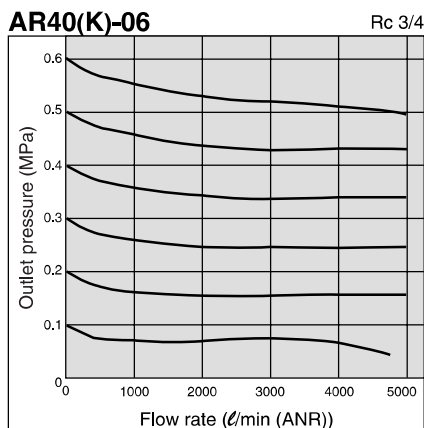
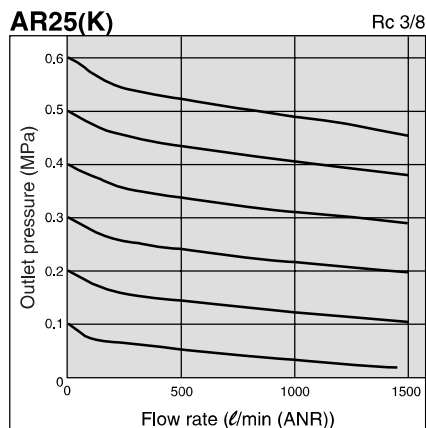
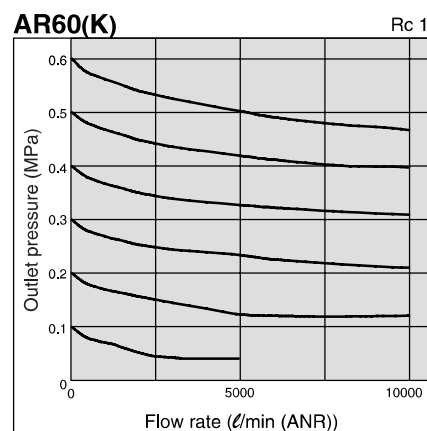
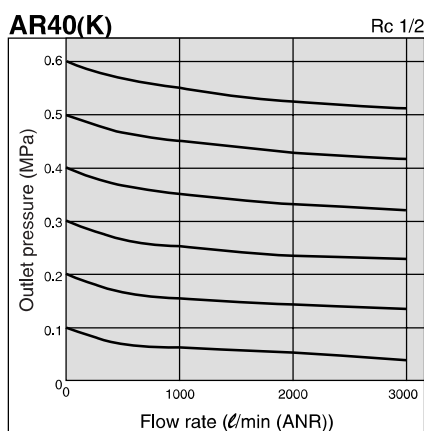
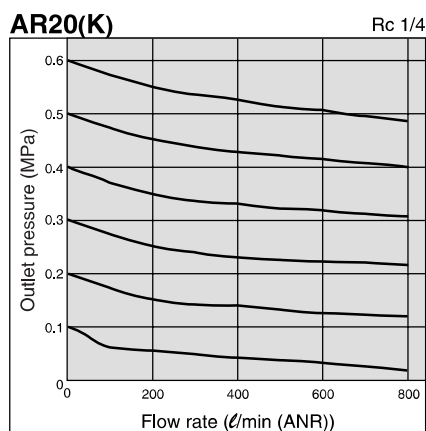
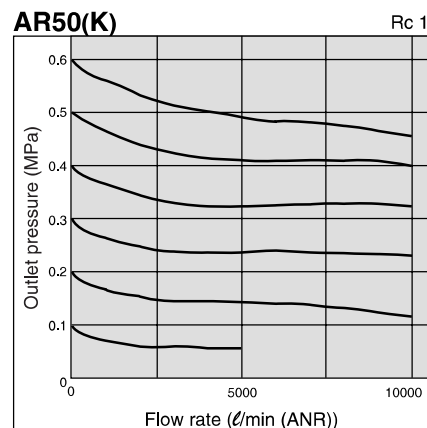
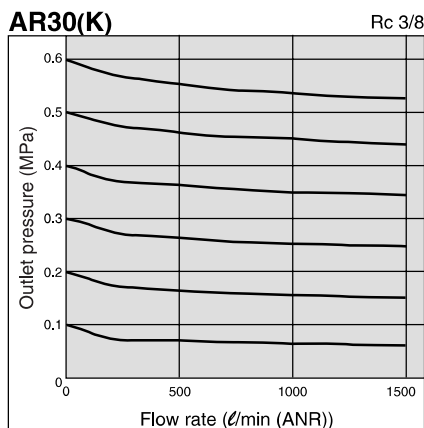
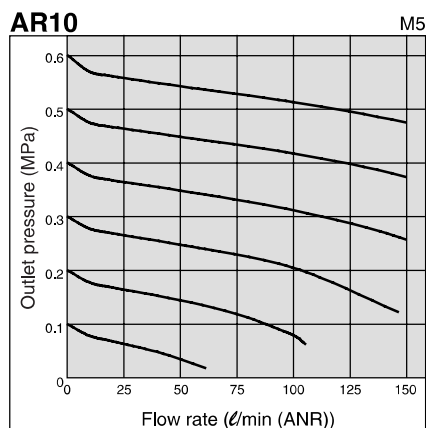

AC

AF□

**AR**

AL

AW□

A□G

AV

AF800  
AF900

# Series AR10 to AR60

## Series AR20K to AR60K

### Pressure Characteristics (Representative values)

Conditions: Inlet pressure 0.7 MPa, Outlet pressure 0.2 MPa, Flow rate 20 l/min (ANR)

**AR10**

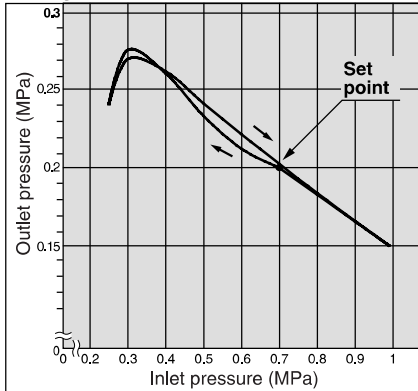

**AR30(K)**

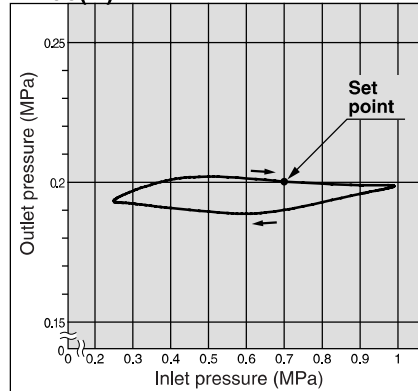

**AR50(K)**

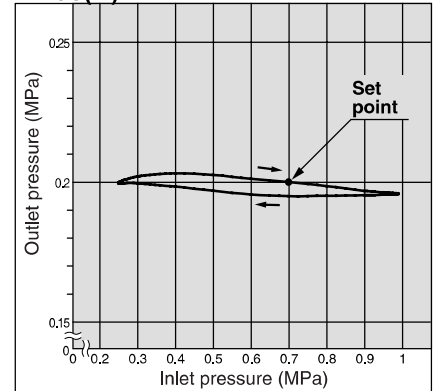

**AR20(K)**

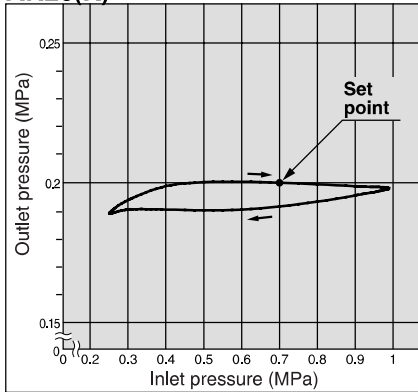

**AR40(K)**

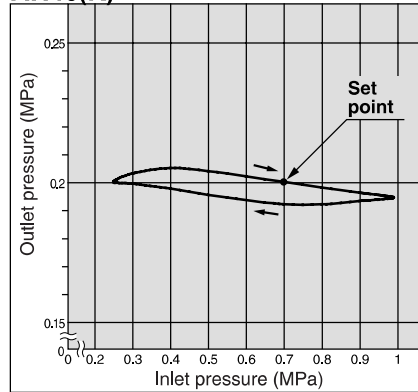

**AR60(K)**

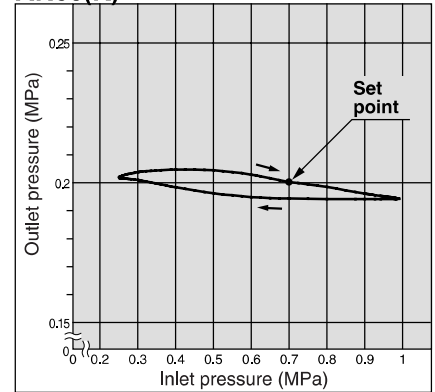

**AR25(K)**

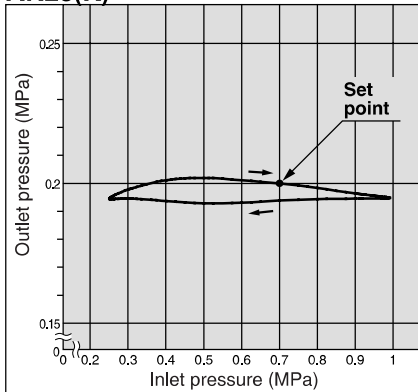

**AR40(K)-06**

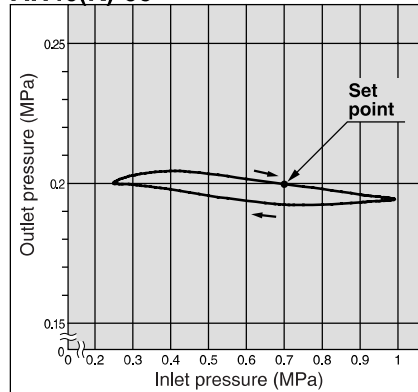

# Regulator *Series AR10 to AR60*

## Regulator with Backflow Function *Series AR20K to AR60K*

### Construction

**AR10**

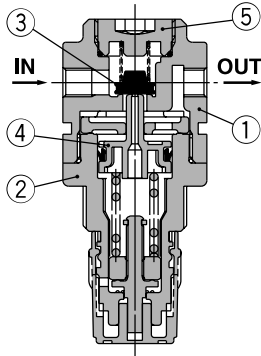

**AR20(K), AR25(K)**

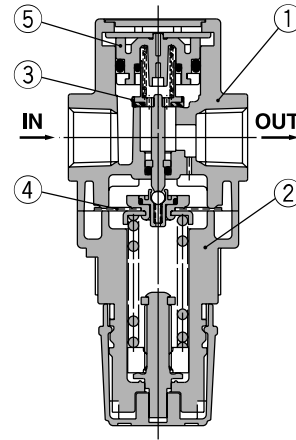

**AR30(K), AR40(K)**

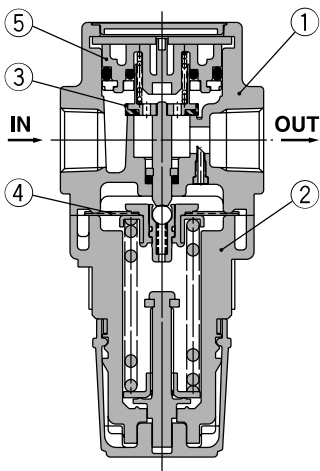

**AR50(K), AR60(K)**

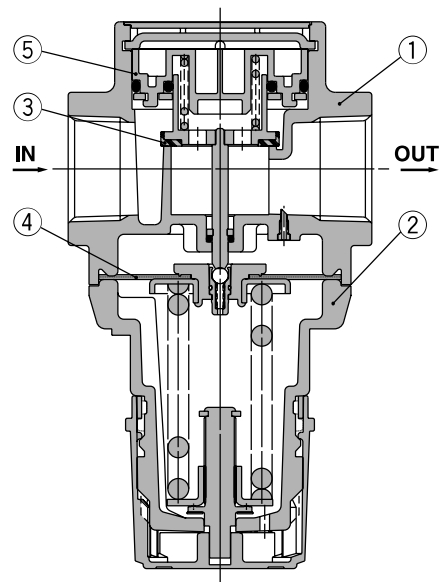

**AR20K to AR60K (Regulator with Backflow Function)**

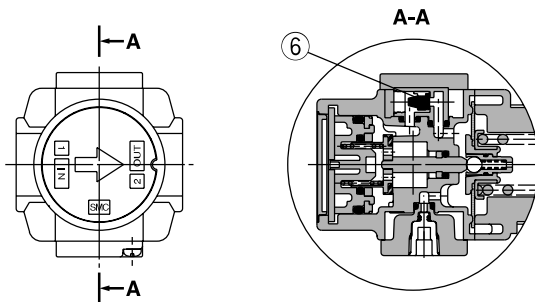

### Component Parts

No.	Description	Material	Model	Color
1	Body	Zinc die-cast	AR10, AR20(K)	Platinum silver
		Aluminum die-cast	AR25(K) to AR60(K)	
2	Bonnet	Polyacetal	AR10, AR20(K) to AR40(K)-06	Black
		Aluminum die-cast	AR50(K), AR60(K)	

### Replacement Parts

No.	Description	Material	Part no.						
			AR10	AR20(K)	AR25(K)	AR30(K)	AR40(K)	AR40(K)-06	AR50(K)
3	Valve assembly	Brass, HNBR	AR10P-090S	AR20P-410S	AR25P-410S	AR30P-410S	AR40P-410S	AR50P-410S	AR60P-410S
4	Diaphragm assembly	Weatherable NBR	AR10P-150AS <sup>Note 1)</sup>	AR20P-150AS	AR25P-150AS	AR30P-150AS	AR40P-150AS	AR50P-150AS	
5	Valve guide assembly	Polyacetal	131329	AR20P-050AS	AR25P-050AS	AR30P-050AS	AR40P-050AS	AR50P-050AS	AR60P-050AS
6	Check valve assembly <sup>Note 2)</sup>	—	—	AR20KP-020AS					

Note 1) The AR10 is a piston type. Assembly of a piston and a seal (KSYP-13).

Note 2) Check valve assembly is applicable for a regulator with backflow function (AR20K to AR60K) only.

Assembly of a check valve cover, check valve body assembly and 2 screws

AC  
AF□  
AR  
AL  
AW□  
A□G  
AV  
AF800  
AF900

# Series AR10 to AR60

## Series AR20K to AR60K

### Working Principle (Regulator with Backflow Function)

#### AR10

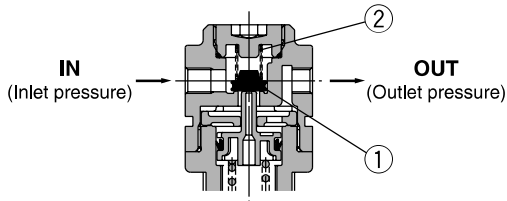

Figure 1

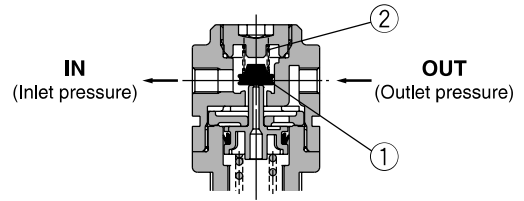

Figure 2

When the inlet pressure is higher than the regulating pressure, the check valve operates as a normal regulator (Figure 1). When the inlet pressure is shut off and exhausted, any inlet pressure applied to the valve ① will be lost. The force for seating the valve ① is the valve spring force ② only. When the valve ① is opened using the outlet force, the outlet pressure will be exhausted at the inlet side. (Figure 2)  
When the set pressure is 0.15 MPa or less, valve ① may not open due to the valve spring ② force.

#### AR20K to AR60K

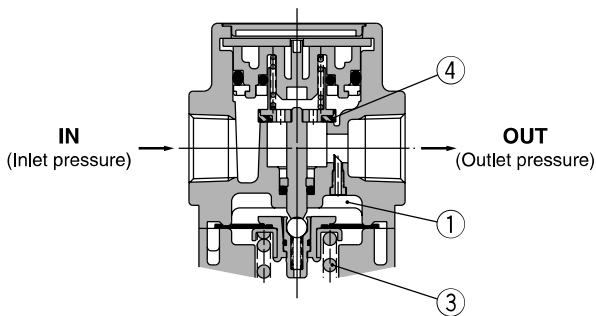
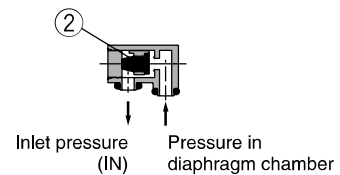
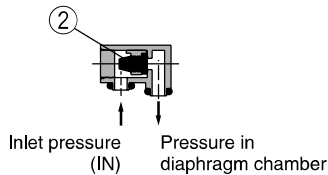
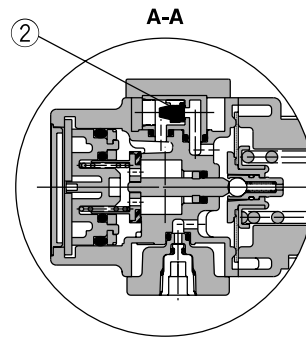
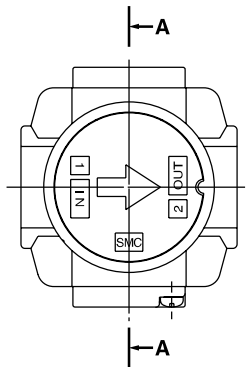

Figure 1 Normal

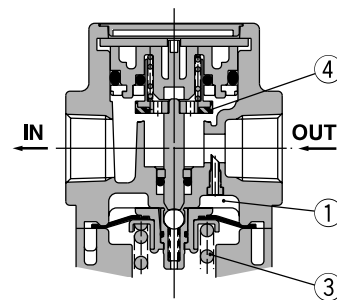

Figure 2 Backflow

When the inlet pressure is higher than the regulating pressure, the check valve ② closes and operates as a normal regulator (Figure 1). When the inlet pressure is shut off and released, the check valve ② opens and the pressure in the diaphragm chamber ① is released into the inlet side (Figure 2). This lowers the pressure in the diaphragm chamber ① and the force generated by the pressure regulator spring ③ lifts the diaphragm. Valve ④ opens through the stem, and the outlet pressure is released to the inlet side (Figure 2).

# Regulator *Series AR10 to AR60*

## Regulator with Backflow Function *Series AR20K to AR60K*

### Dimensions

#### AR10, AR20(K) to AR40(K)-06

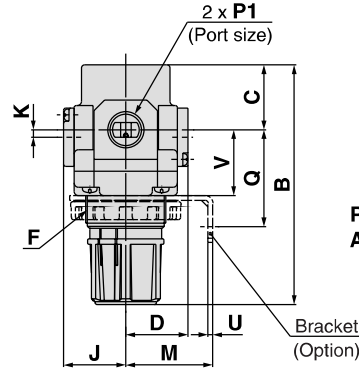
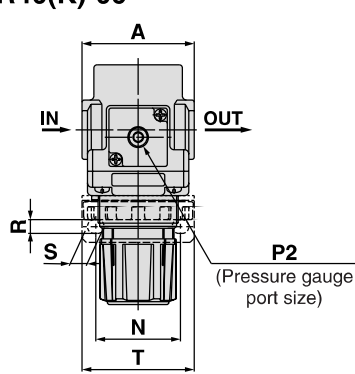

Panel fitting dimension

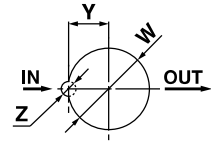
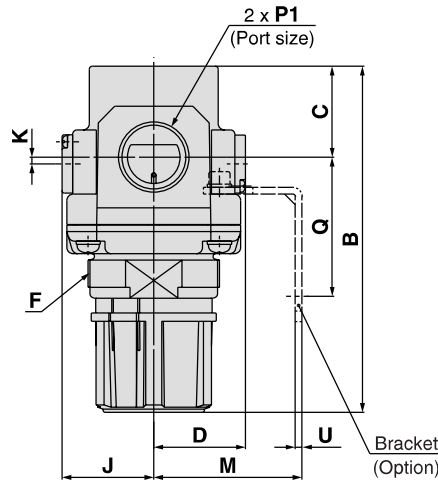
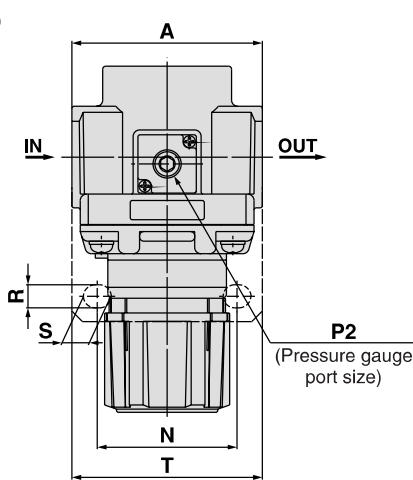
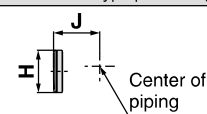
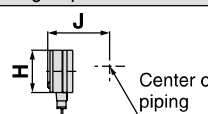
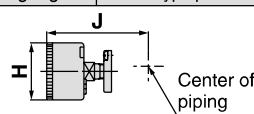

Plate thickness  
AR10, AR20(K) to AR30(K): Max. 3.5  
AR40(K): Max. 5

#### AR50(K), AR60(K)



Applicable model	AR20(K) to AR60(K)		AR10, AR20(K) to AR60(K)	AR20(K) to AR60(K)
Option	Square embedded type pressure gauge	Digital pressure switch	Round type pressure gauge	Round type pressure gauge (with color zone)
Dimensions				

Model	Standard specifications										Optional specifications						
	P1	P2	A	B <sup>Note 1)</sup>	C	D	F	J	K	H	J	H	J	H	J	H	J
AR10	M5 x 0.8	1/16	25	58	11	12.5	M18 x 1	13	0	—	—	—	—	ø26	26	—	—
AR20(K)	1/8, 1/4	1/8	40	94	26.5	28.5	M28 x 1	28.5	2 <sup>Note 2)</sup>	□28	29.5	□27.8	40	ø37.5	65	ø37.5	65
AR25(K)	1/4, 3/8	1/8	53	101	28	27.5	M32 x 1.5	27.5	0	□28	28.5	□27.8	39	ø37.5	64	ø37.5	64
AR30(K)	1/4, 3/8	1/8	53	116	31	29.5	M38 x 1.5	29.5	3.5	□28	30.5	□27.8	41	ø37.5	66	ø37.5	66
AR40(K)	1/4, 3/8, 1/2	1/4	70	128	36	34	M42 x 1.5	34	3.5	□28	35	□27.8	45	ø42.5	74	ø42.5	74
AR40(K)-06	3/4	1/4	75	129	36	34	M42 x 1.5	34	3	□28	35	□27.8	45	ø42.5	74	ø42.5	74
AR50(K)	3/4, 1	1/4	90	169	43	43.5	M62 x 1.5	43.5	3.3	□28	44.5	□27.8	55	ø42.5	84	ø42.5	84
AR60(K)	1	1/4	95	176	46	43.5	M62 x 1.5	43.5	3.3	□28	44.5	□27.8	55	ø42.5	84	ø42.5	84

Model	Optional specifications											
	Bracket mount							Panel mount				
	M	N	Q	R	S	T	U	V	W	Y	Z	
AR10	25	28	30	4.5	6.5	40	2	18	18.5	—	—	
AR20(K)	30	34	44	5.4	15.4	55	2.3	25	28.5	14	6	
AR25(K)	30	34	44	5.4	15.4	55	2.3	26	32.5	16	6	
AR30(K)	41	40	46	6.5	8	53	2.3	31	38.5	19	7	
AR40(K)	50	54	54	8.5	10.5	70	2.3	35.5	42.5	21	7	
AR40(K)-06	50	54	56	8.5	10.5	70	2.3	37	42.5	21	7	
AR50(K)	70	66	65.8	11	13	90	3.2	—	—	—	—	
AR60(K)	70	66	65.8	11	13	90	3.2	—	—	—	—	

Note 1) The total length of B dimension is the length when the filter regulator knob is unlocked.  
Note 2) For the AR20 only, the position of the pressure gauge is above the center of the piping.

- AC
- AF□
- AR
- AL
- AW□
- A□G
- AV
- AF800
- AF900

# Regulator AR20 to AR60

## Made to Order Specifications:

Please contact SMC for detailed dimensions, specifications, and lead times.



AR30-03-X425

### ① Special Temperature Environment

Special materials are used in the manufacturing of seals and resin parts to allow them to withstand various temperature conditions in cold or tropical (hot) climates.

#### Specifications

Made-to-order part no.	-X430	-X440
<b>Environment</b>	Low temperature	High temperature
<b>Ambient temperature (°C)</b>	-30 to 60	-5 to 80
<b>Fluid temperature (°C)</b>	-5 to 60 (with no freezing)	
<b>Material</b>	<b>Rubber parts</b>	Special NBR
	<b>Main parts</b>	Metal (Aluminum die-cast), etc.

#### Applicable Model

Model	AR25	AR30	AR40	AR40-06	AR50	AR60
<b>Port size</b>	1/4, 3/8	1/4, 3/8	1/4, 3/8, 1/2	3/4	3/4, 1	1

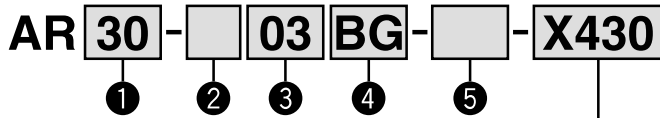

- Option/Semi-standard: Select one each for a to g.
- Option/Semi-standard symbol: When more than one specification is required, indicate in alphanumeric order.  
Example) AR30-03BG-1NR-X430

For high/low temperature

<b>X430</b>	Low temperature
<b>X440</b>	High temperature

	Symbol	Description	① Body size					
			25	30	40	50	60	
② Thread type	Nil	Rc	●	●	●	●	●	
	N	NPT	●	●	●	●	●	
	F	G	●	●	●	●	●	
+								
③ Port size	02	1/4	●	●	●	—	—	
	03	3/8	●	●	●	—	—	
	04	1/2	—	—	●	—	—	
	06	3/4	—	—	●	●	—	
	10	1	—	—	—	●	●	
+								
④ Option	a Mounting	Nil	Without mounting option	●	●	●	●	●
		B	With bracket	●	●	●	●	●
		H	With set nut (for panel fitting)	●	●	●	—	—
+								
b Pressure gauge	G	Nil	Round type pressure gauge (without limit indicator)	●	●	●	●	●
		G	Round type pressure gauge (with limit indicator)	●	●	●	●	●
+								
c Set pressure	1	Nil	0.05 to 0.85 MPa setting	●	●	●	●	●
		1	0.02 to 0.2 MPa setting	●	●	●	●	●
+								
d Exhaust mechanism	Nil	N	Relieving type	●	●	●	●	●
		N	Non-relieving type	●	●	●	●	●
+								
e Flow direction	Nil	R	Flow direction: Right to left	●	●	●	●	●
		R	Flow direction: Left to right	●	●	●	●	●
+								
f Knob	Nil	Y	Upward	●	●	●	●	●
		Y	Downward	●	●	●	●	●
+								
g Pressure unit	Nil	Nil	Name plate and pressure gauge in imperial units: MPa	●	●	●	●	●
		Z	Name plate and caution plate for bowl in imperial units: psi	○	○	○	○	○
+								
			Note 6)	Note 6)	Note 6)	Note 6)	Note 6)	

- Note 1) Option B, G, H are not assembled and supplied loose at the time of shipment.  
 Note 2) Assembly of a bracket and set nuts (AR25 to AR40) Including 2 mounting screws for the AR50 and AR60  
 Note 3) Mounting thread for pressure gauge: 1/8 for the AR25 to AR30; 1/4 for the AR40 to AR60. Pressure gauge type: G43  
 Note 4) The only difference from the standard specifications is the adjusting spring for the regulator. It does not restrict the setting of 0.2 MPa or more. When the pressure gauge is attached, a 0.2 MPa pressure gauge will be fitted.  
 Note 5) For thread type: NPT. This product is for overseas use only according to the new Measurement Law. (The SI unit type is provided for use in Japan.)  
 Note 6) ○: For thread type: NPT only

### ② High Pressure

Strong materials are used in the manufacturing of air filters intended for high pressure operation. Also, construction modification allows a wider regulating pressure range.

#### Specifications

Made-to-order part no.	-X425
<b>Proof pressure (MPa)</b>	3.0
<b>Maximum operating pressure (MPa)</b>	2.0
<b>Set pressure range (MPa)</b>	0.1 to 1.6
<b>Ambient and fluid temperature (°C)</b>	-5 to 60 (with no freezing)

#### Applicable Model

Model	AR20	AR25	AR30	AR40	AR40-06	AR50	AR60
<b>Port size</b>	1/8, 1/4	1/4, 3/8	1/4, 3/8	1/4, 3/8, 1/2	3/4	3/4, 1	1

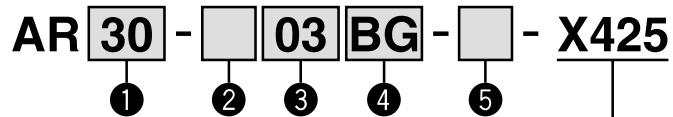

For high pressure

- Option/Semi-standard: Select one each for a to f.
- Option/Semi-standard symbol: When more than one specification is required, indicate in alphabetic order.  
Example) AR30-03BG-NR-X425

	Symbol	Description	① Body size						
			20	25	30	40	50	60	
② Thread type	Nil	Rc	●	●	●	●	●	●	
	N	NPT	●	●	●	●	●	●	
	F	G	●	●	●	●	●	●	
+									
③ Port size	01	1/8	●	—	—	—	—	—	
	02	1/4	●	●	●	●	—	—	
	03	3/8	—	●	●	●	—	—	
	04	1/2	—	—	●	●	—	—	
	06	3/4	—	—	—	●	●	—	
+									
④ Option	a Mounting	Nil	Without mounting option	●	●	●	●	●	●
		B	With bracket	●	●	●	●	●	●
		H	With set nut (for panel fitting)	●	●	●	—	—	—
+									
b Pressure gauge	G	Nil	Round type pressure switch (with limit indicator)	●	●	●	●	●	●
		G	Round type pressure switch (with limit indicator)	●	●	●	●	●	●
+									
c Exhaust mechanism	Nil	N	Relieving type	●	●	●	●	●	●
		N	Non-relieving type	●	●	●	●	●	●
+									
d Flow direction	Nil	R	Flow direction: Right to left	●	●	●	●	●	●
		R	Flow direction: Left to right	●	●	●	●	●	●
+									
e Knob	Nil	Y	Upward	●	●	●	●	●	●
		Y	Downward	●	●	●	●	●	●
+									
f Pressure unit	Nil	Nil	Name plate and pressure gauge in imperial units: MPa	●	●	●	●	●	●
		Z	Name plate and caution plate for bowl in imperial units: psi	○	○	○	○	○	○
+									
			Note 5)	Note 5)	Note 5)	Note 5)	Note 5)	Note 5)	

- Note 1) Option B, G, H are not assembled and supplied loose at the time of shipment.  
 Note 2) Assembly of a bracket and set nuts (AR20 to AR40) Including 2 mounting screws for the AR50 and AR60  
 Note 3) Mounting thread for pressure gauge: 1/8 for AR20 to AR30, 1/4 for AR40 to AR60. Pressure gauge type: G46-20-□  
 Note 4) For thread type: NPT. This product is for overseas use only according to the new Measurement Law. (The SI unit type is provided for use in Japan.)  
 Note 5) ○: For thread type: NPT only

# Regulator AR10 to AR60

## Regulator with Backflow Function AR20K to AR60K

# Made to Order Specifications:



Please contact SMC for detailed dimensions, specifications, and lead times.

### ③ 0.4 MPa Setting

The maximum set pressure is 0.4 MPa. When a pressure gauge is included, the display will show a range from 0 to 0.4 MPa.

#### Specifications

Proof pressure	1.5 MPa
Maximum operating pressure	1.0 MPa
Set pressure range	0.05 to 0.4 MPa

#### Applicable Model

Model	AR10	AR20(K)	AR25(K)	AR30(K)	AR40(K)	AR40(K)-06	AR50(K)	AR60(K)
Port size	M5	1/8, 1/4	1/4, 3/8	1/4, 3/8	1/4, 3/8, 1/2	3/4	3/4, 1	1

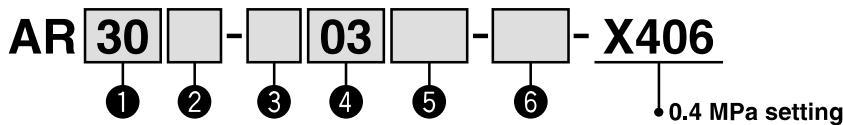

- Option/Semi-standard: Select one each for a to f.
- Option/Semi-standard symbol: When more than one specification is required, indicate in alphabetic order. Example) AR30K-03BE-NR-X406

		Symbol	Description	① Body size							
				10	20	25	30	40	50	60	
②	With backflow function	Nil	Without backflow function	●	●	●	●	●	●	●	
		K <small>Note 1)</small>	With backflow function	—	●	●	●	●	●	●	
③	Thread type	Nil	Metric thread (M5)	●	—	—	—	—	—	—	
		Rc		—	●	●	●	●	●	●	
		NPT		—	●	●	●	●	●	●	
		G		—	●	●	●	●	●	●	
④	Port size	M5	M5	●	—	—	—	—	—	—	
		01	1/8	—	●	—	—	—	—	—	
		02	1/4	—	●	●	—	—	—	—	
		03	3/8	—	—	●	●	—	—	—	
		04	1/2	—	—	—	—	●	—	—	
		06	3/4	—	—	—	—	—	●	—	
⑤	a	Mounting	Nil	Without mounting option	●	●	●	●	●	●	●
			B <small>Note 3)</small>	With bracket	●	●	●	●	●	●	●
			H	With set nut (for panel fitting)	●	●	●	●	●	—	—
	b	Pressure gauge	Nil	Without pressure gauge	●	●	●	●	●	●	●
			E	Square embedded type pressure gauge (with limit indicator)	—	●	●	●	●	●	●
			G	Round type pressure gauge (without limit indicator)	●	—	—	—	—	—	—
			M	Round type pressure gauge (with limit indicator)	—	●	●	●	●	●	●
	c	Digital pressure switch	E1 <small>Note 4)</small>	Output: NPN output / Electrical entry: Wiring bottom entry	—	●	●	●	●	●	●
			E2 <small>Note 4)</small>	Output: NPN output / Electrical entry: Wiring top entry	—	●	●	●	●	●	●
			E3 <small>Note 4)</small>	Output: PNP output / Electrical entry: Wiring bottom entry	—	●	●	●	●	●	●
E4 <small>Note 4)</small>			Output: PNP output / Electrical entry: Wiring top entry	—	●	●	●	●	●	●	
⑥	c	Exhaust mechanism	Nil	Relieving type	●	●	●	●	●	●	
			N	Non-relieving type	●	●	●	●	●	●	
	d	Flow direction	Nil	Flow direction: Left to right	●	●	●	●	●	●	
			R	Flow direction: Right to left	●	●	●	●	●	●	
	e	Knob	Nil	Downward	●	●	●	●	●	●	
			Y	Upward	●	●	●	●	●	●	
f	Pressure unit	Nil	Name plate and pressure gauge in imperial units: MPa	○ <small>Note 7)</small>	○ <small>Note 7)</small>	○ <small>Note 7)</small>	○ <small>Note 7)</small>	○ <small>Note 7)</small>	○ <small>Note 7)</small>	○ <small>Note 7)</small>	
		Z <small>Note 5)</small>	Name plate and pressure gauge in imperial units: psi	—	△ <small>Note 8)</small>	△ <small>Note 8)</small>	△ <small>Note 8)</small>	△ <small>Note 8)</small>	△ <small>Note 8)</small>	△ <small>Note 8)</small>	
		ZA <small>Note 6)</small>	Digital pressure switch: With unit switching function	—	△ <small>Note 8)</small>	△ <small>Note 8)</small>	△ <small>Note 8)</small>	△ <small>Note 8)</small>	△ <small>Note 8)</small>	△ <small>Note 8)</small>	

- Note 1) The AR10 type comes with a backflow function as a standard feature. (K is not available.) When using the AR10 type as w/ backflow function, backflow may not occur with the set pressure 0.15 MPa or less. Please set the inlet pressure to at least 0.05 MPa higher than the set pressure.
- Note 2) Option B, G, H are not assembled and supplied loose at the time of shipment.
- Note 3) Assembly of a bracket and set nuts (AR10, AR20(K) to AR40(K)) Including 2 mounting screws for the AR50(K), AR60(K)
- Note 4) When choosing with H (panel mount), the installation space for lead wires will not be secured. In this case, select "wiring top entry" for the electrical entry.

- (Select "wiring bottom entry" when the semi-standard Y is chosen simultaneously.)
- Note 5) For thread type: M5 and NPT. This product is for overseas use only according to the new Measurement Law. (The SI unit type is provided for use in Japan.) The digital pressure switch will be equipped with the unit conversion function, setting to psi initially.
- Note 6) For options: E1, E2, E3, E4. This product is for overseas use only according to the new Measurement Law. (The SI unit is provided for use in Japan.)
- Note 7) ○: For thread type: M5 and NPT only
- Note 8) △: Select with options: E1, E2, E3, E4.

- AC
- AF□
- AR
- AL
- AW□
- A□G
- AV
- AF800
- AF900

# Pilot Operated Regulator

## Series AR425 to 935

### Standard Specifications

Model	AR425	AR435	AR625	AR635	AR825	AR835	AR925	AR935
Port size	1/4, 3/8, 1/2		3/4, 1		1 1/4, 1 1/2		2	
Fluid	Air							
Proof pressure	1.5 MPa							
Max. operating pressure	1.0 MPa							
Set pressure range (MPa) <sup>(1)</sup>	0.05 to 0.83	0.02 to 0.2	0.05 to 0.83	0.02 to 0.2	0.05 to 0.83	0.02 to 0.2	0.05 to 0.83	0.02 to 0.2
Air consumption (for bleed hole) <sup>(2)</sup>	5 l/min (ANR) (at maximum pressure)							
Pressure gauge port size	1/4							
Ambient and fluid temperature	-5 to 60°C (No freezing)							
Construction	Internal pilot relieving type (Pilot air is always bleeding.)							
Mass (kg)	0.7		1.1		2.5		4.5	

- Note 1) Outlet pressure range: P2 is 90% of P1 or less.  
 Note 2) Air consumption differs depending on the set pressure. Due to the construction, the pressure gap between inlet and outlet cannot be set within 0.03 MPa, even if the handle is set at the maximum.

### Accessory (Option)/Part No.

Description	Model	Part no.			
		AR4□5	AR6□5	AR8□5	AR9□5
Bracket		B24P	B25P	—	—
Pressure gauge with limit indicator <sup>Note 1)</sup>		G46-10-□02 (Max. 1.0 MPa), G46-2-□02 (Max. 0.2 MPa)			

- Note 1) • In the gauge part no. (e.g. G46-10-□02), □ indicate kind of the connecting thread. Put nothing for Rc and "N" for NPT thread.  
 • Please consult with SMC for NPT pressure gauge.  
 Note 2) Use caution not to tighten excessively when mounting a pressure gauge, otherwise it may result in a breakdown. Use a pipe tape for sealing. Recommended torque: 12 to 14 N·m.

### How to Order

#### Internal pilot operated relieving type regulator

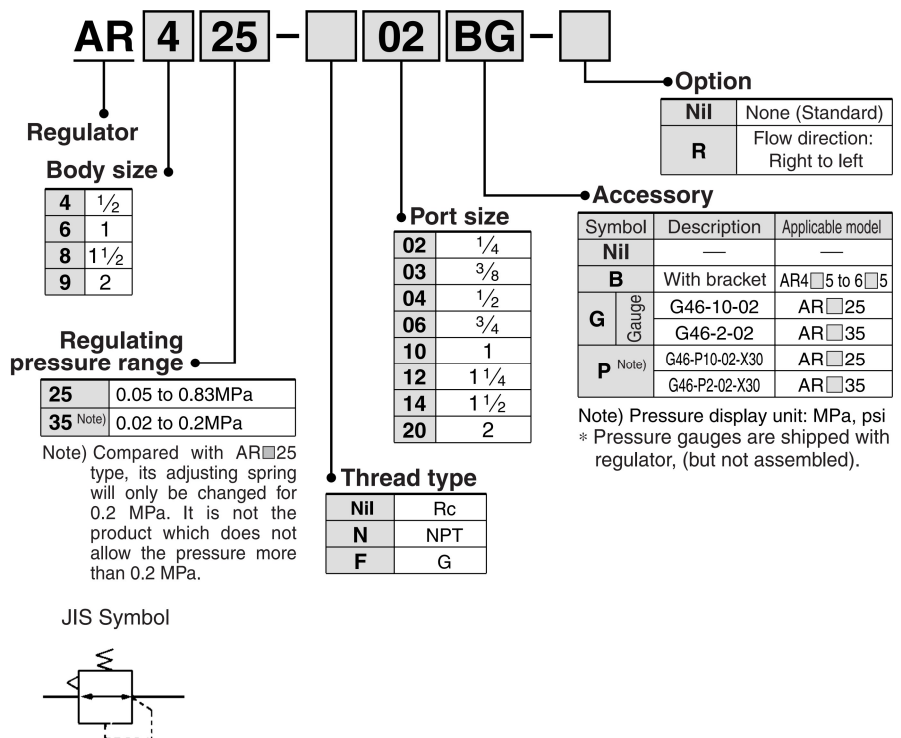
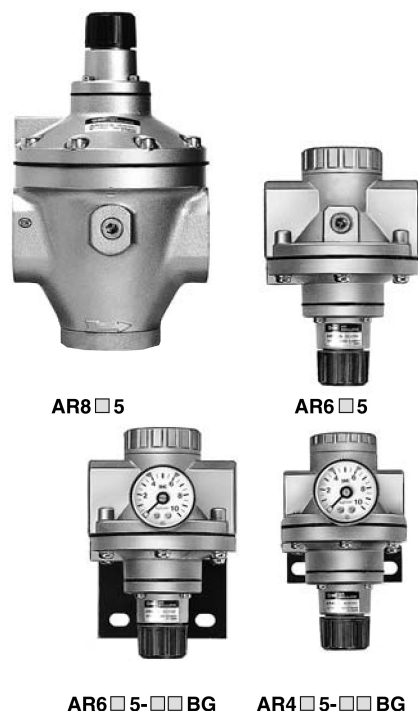

AR6□5-□□BG AR4□5-□□BG

# Pilot Operated Regulator *Series AR425 to 935*

## Flow Characteristics (Representative values)

Inlet pressure: 0.7 MPa

## Pressure Characteristics (Representative values)

Conditions:  
Inlet pressure 0.7 MPa  
Outlet pressure 0.2 MPa  
Flow rate: 20 ℓ/min (ANR)

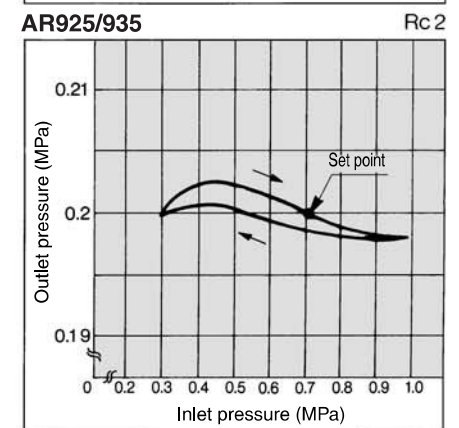
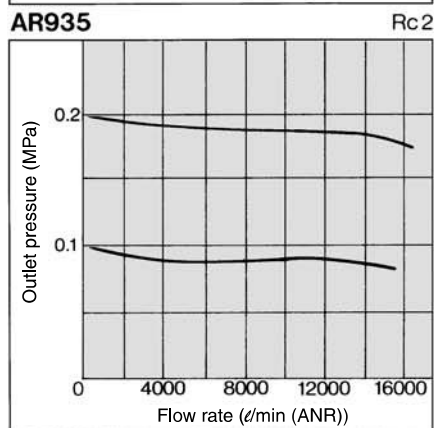
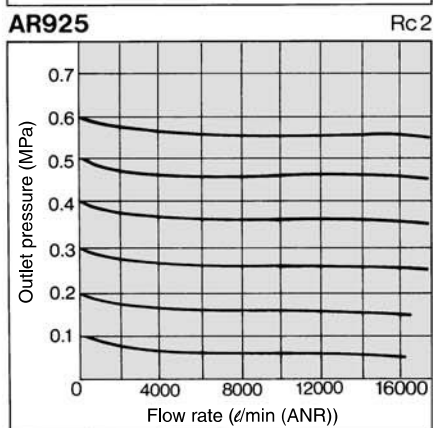
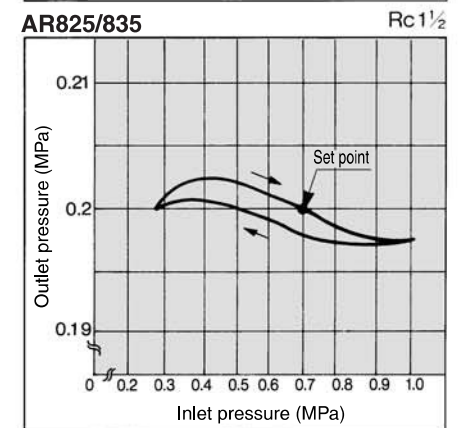
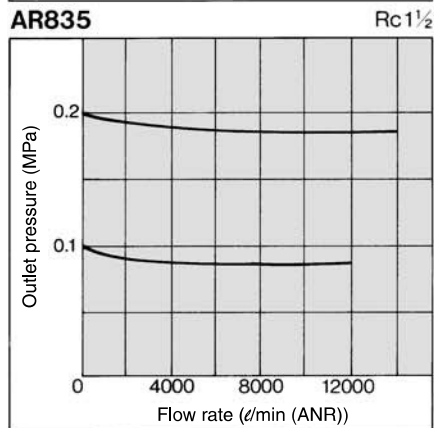
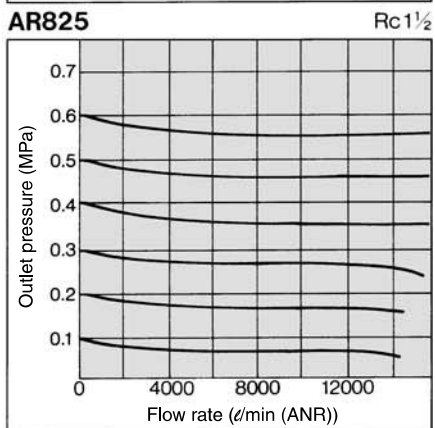
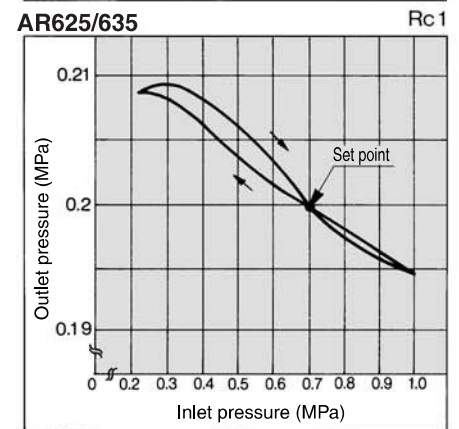
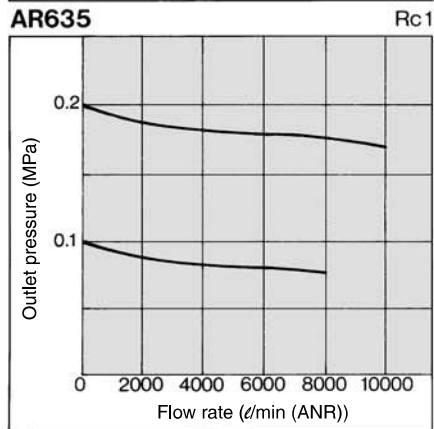
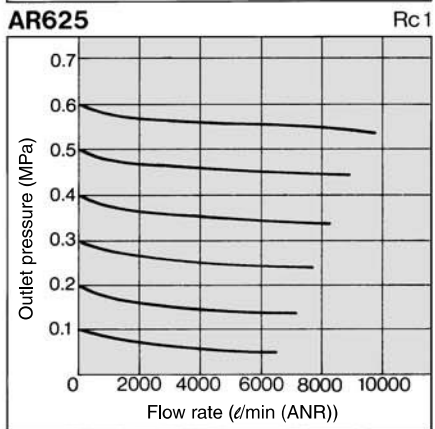
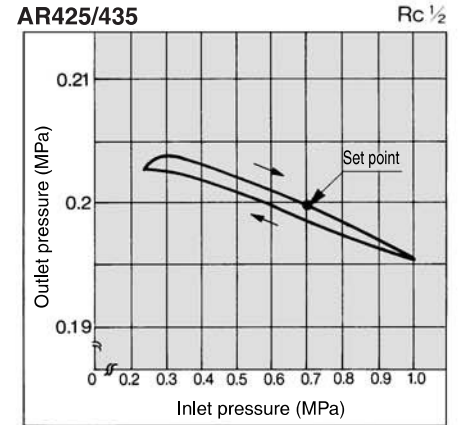
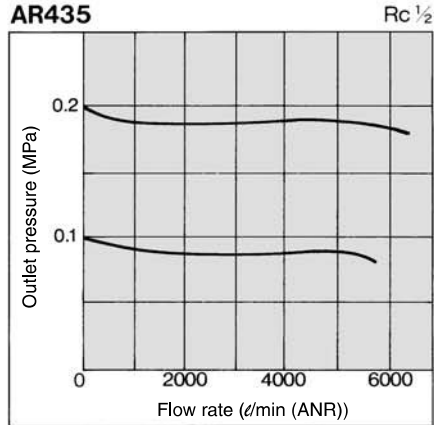
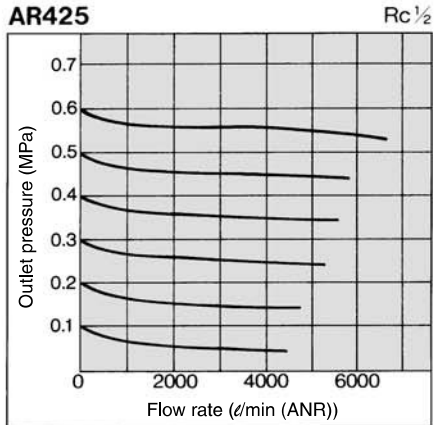

ARJ

AR425 to 935

AMR

ARM

ARP

IR

IRV

VEX1 □

SRH

SRP

SRF

ARX20

VCHR

ITV

IC

PVQ

VEF  
VEP

VER

VEA

VY2

VBA  
VBAT

AP100

# Series AR425 to 935

## Construction

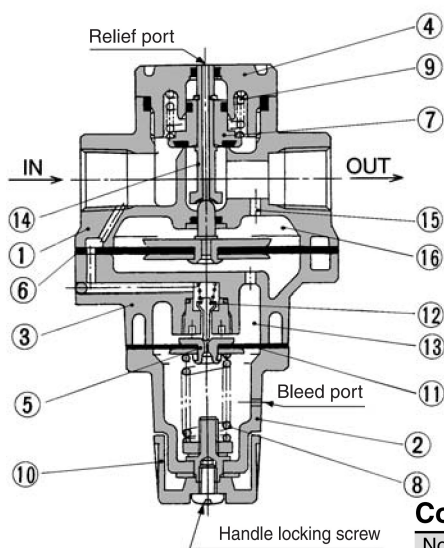

When handle ⑩ is turned clockwise to compress pressure adjustment spring ⑧, the pressure from the IN side passes through diaphragm ⑪, opens pilot valve ⑫, and enters upper pilot chamber ⑬. This pressure and the force generated by pressure adjustment spring ⑧ act as resistance, resulting in equilibrium. Then, this pressure passes through diaphragm ⑥ of the main valve and stem ⑭, and pushes valve (main valve) ⑦ open, thus guiding the pressure to the OUT side. At the same time, the pressure passes through feedback hole ⑮, and enters diaphragm chamber ⑯, thus establishing the OUT side pressure (outlet pressure).

### Component Parts

No.	Description	Material	Note
1	<b>Body</b>	Aluminum die-casted *	Platinum silver painted
2	<b>Bonnet</b>	Aluminum die-casted	Platinum silver painted
3	<b>Chamber</b>	Aluminum die-casted	Platinum silver painted
4	<b>Valve guide</b>	Zinc die-casted *	Platinum silver painted

\* In the case of AR825/835/925/935, the material is aluminum alloy.

### Replacement Parts

No.	Description	Material	Qty.	Part no.			
				AR425, 435	AR625, 635	AR825, 835	AR925, 935
5, 11	Exhaust valve assembly <small>(Note)</small>	—	1	132586A	132586A	132586A	132586A
6	Main valve side diaphragm assembly	—	1	132581A	132659A	13275A	13285A
7	Valve assembly	—	1	132572A	132653A	132752A	132829A
8	Adjusting spring	Steel wire	1	135053 (AR425) 135025 (AR435)	135053 (AR625) 135025 (AR635)	135053 (AR825) 135025 (AR835)	135053 (AR925) 135025 (AR935)
9	Valve spring	Stainless steel	1	135211	132656	132713	13289
10	Handle	ABS	1	13414			

Note) Diaphragm is included.

## ⚠ Precautions

Be sure to read before handling. Refer to front matters 42 and 43 for Safety Instructions and pages 287 to 291 for Precautions on every series.

### Mounting/Adjustment

#### ⚠ Warning

1. Install the valve guide (on the opposite side of the handle) 60 mm away from the ground surface to facilitate maintenance inspection.
2. Do not use the regulator with flow exceeding the Max. flow indicated in "Flow Characteristics" as this can cause failure in pressure adjustment.

#### ⚠ Caution

1. Release the lock to adjust the pressure. After the adjustment, engage the lock. Failure to observe this procedure could damage the handle or cause the outlet pressure to fluctuate.  
<Lock operating method>  
Loosen the handle locking screw to unlock it, and tighten it to lock it.
2. Please contact SMC if this product is to be used between solenoid valve and actuator.

## Dimensions

AR425/435  
AR625/635

AR825/835  
AR925/935

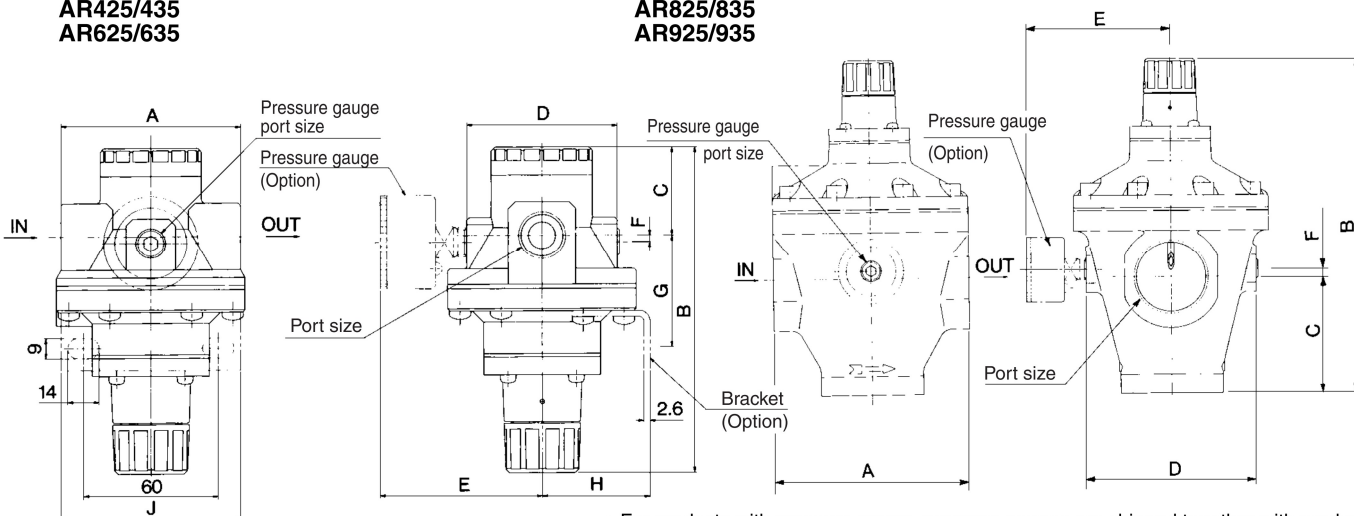

\* For products with pressure gauge, pressure gauges are shipped together with product.

Model	Port size	Pressure gauge port size	A	B	C	D	E	F	Bracket dimensions			Bracket part no.
									G	H	J	
AR425/435	1/4, 3/8, 1/2	1/4	80	145.5	39.5	67	73	3	46.5	48	80	B24P
AR625/635	3/4, 1	1/4	98	155	43	78	78.5	7	85	52	90	B25P
AR825/835	1 1/4, 1 1/2	1/4	126	216	75	110	94.5	5	—	—	—	—
AR925/935	2	1/4	160	241	90	140	109.5	10	—	—	—	—



**SMC Corporation of America**

10100 SMC Boulevard

Noblesville, IN 46060

www.smcusa.com

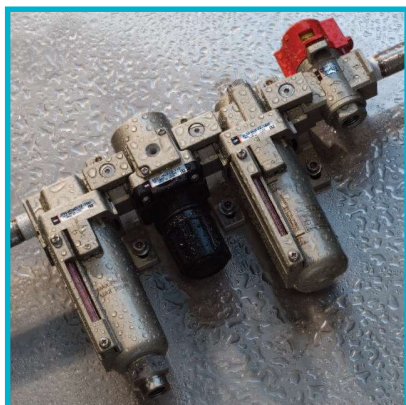

## *P.G. Information*

# *Epoxy Coated F.R.L. Units*

*AC21/31/41-\*\*\*-\*-X2217*

*AF20/30/40-\*\*\*-\*-X480*

*AR20/30/40-\*\*\*-\*-X48*

*AL20/30/40-\*\*\*-\*-X480*

*AW20/30/40-\*\*\*-\*-X48*

*VHS20/30/40-\*\*\*-\*-X513*

*Y20/30/40\*-T4*

**Application:** Air preparation in an environment that requires enhanced corrosion protection.

Feature 1: Die cast aluminum components are epoxy coated for improved chemical resistance.

Feature 2: Steel external hardware is replaced with stainless steel for improved chemical resistance.

### **Comparison with Standard Product:**

- 1) Functional performance is equivalent to standard product.
- 2) Product withstood salt spray testing per ASTM B117-07A with excellent results (See test results on page 12). Improved performance vs. other chemicals is anticipated but has not been verified.

### **Applications:**

- Marine environments
- Water splash zone in various processes
- Washdown in food plants (non-food or splash zone only)

### **Related Products:**

- KQG Series - 316 SUS One-touch Fittings - Coming Soon: KQG2
- KQB2 Series - Ni plated brass One-touch Fittings (Coming Soon)
- ASG Series - 316 SUS One-touch Speed Controls
- CG5 Series - repairable 304 SUS Cylinder
- NCM Series with X6009 option - crimped body 304 SUS Cylinder, domestic interchange
- CJ5 Series - crimped body 304 SUS Cylinder
- HY Series - Aluminum body Hygienic Design Actuators

How To Order

AC 31 B - N 03 D - V - 8 Y Z - X2217

Air Combination Unit

Body Size

Symbol	Size
21	1/8
31	3/8
41	1/2

Model Combination

Symbol	Model / Assembly Order
Nil	AF + AR + AL
A	AW + AL
B	AF + AR

NPT Threads

Port Size

Symbol	Port Size	Applicable Body Size
02	1/4	21
03	3/8	31
04	1/2	41

Note: Other sizes, thread forms, options, etc. may be possible, please contact SMC for availability.

• With External Epoxy Coating, Stainless Fasteners

• Name Plate, Caution Plate On Bowl in psi, °F

• Regulator Handle Orientation

Symbol	Description
Nil	Downward Handle
Y	Upward Handle

• Bowl

Symbol	Description	Applicable Body Size
2	Metal Bowl	21
8	Metal Bowl With Sight Glass	31, 41

• Residual Pressure Relief Valve

Symbol	Description	Applicable Model Combo
Nil	Without Valve	All
V	With Downstream Valve	All

• Accessories

Symbol	Description	Applicable Body Size
Nil	None	All
C	Float Auto Drain (N.C.)	31, 41
D	Float Auto Drain (N.O.)	31, 41

Specifications



Body size	21	31	41
Operating specifications	Same as standard - see catalog ES40-42D or NC160A		
Port size	1/4" NPT	3/8" NPT	1/2" NPT
Auto drain port (AF, AW)	N/A	1/4" NPT	
Bowl type (AF, AL, AW)	Metal		Metal with sight gauge
Body material	Die cast aluminum		
Bowl material (AF, AL, AW)	Die cast aluminum		
Body, Bowl surface treatment	Epoxy resin coating		
Bonnet (AR, AW)	Polyacetal		
Manual drain (AF, AW)	POM		
External screws	Stainless steel 410		
Individual mounting brackets	Epoxy coated steel		
Panel mount nut (AR, AW)	POM		
Connector brackets (AC)	Die cast zinc (epoxy coated)		
Fill plug (AL)	Stainless steel 304		
Sight dome (AL)	Polycarbonate		
Sight glass hardware (AF,AL,AW)	Stainless steel 304		

Dimensions - Refer to drawings on page 3

AC	A*	AA**	B	C	E	F	G	J	K	M	N	Q	U	V	W
AC21	140	190	160	73	—	45.5	40	26	5	30	51	24	5	33	—
AC31	181	245	220	86	30	58.5	55	29.5	3.5	41	64	35	7	45	34.5
AC41	238	322	239	92	38	75.5	80	37.5	1.5	50	81	40	7	50	41

\* Without relief valve option \*\* With relief valve option

AC-A	A*	AA**	B	C	E	F	G	J	K	M	N	Q	U	V	W
AC21A	90	140	160	73	—	45.5	40	26	5	30	51	24	5	33	—
AC31A	117	181	220	86	30	58.5	55	29.5	3.5	41	64	35	7	45	34.5
AC41A	154	238	239	92	38	75.5	80	37.5	1.5	50	81	40	7	50	41

\* Without relief valve option \*\* With relief valve option

AC-B	A*	AA**	B	C	E	F	G	J	K	M	N	Q	U	V	W
AC21B	90	140	160	73	—	45.5	40	26	5	30	51	24	5	33	—
AC31B	117	181	220	86	30	58.5	55	29.5	3.5	41	64	35	7	45	34.5
AC41B	154	238	239	92	38	75.5	80	37.5	1.5	50	81	40	7	50	41

\* Without relief valve option \*\* With relief valve option

## AC

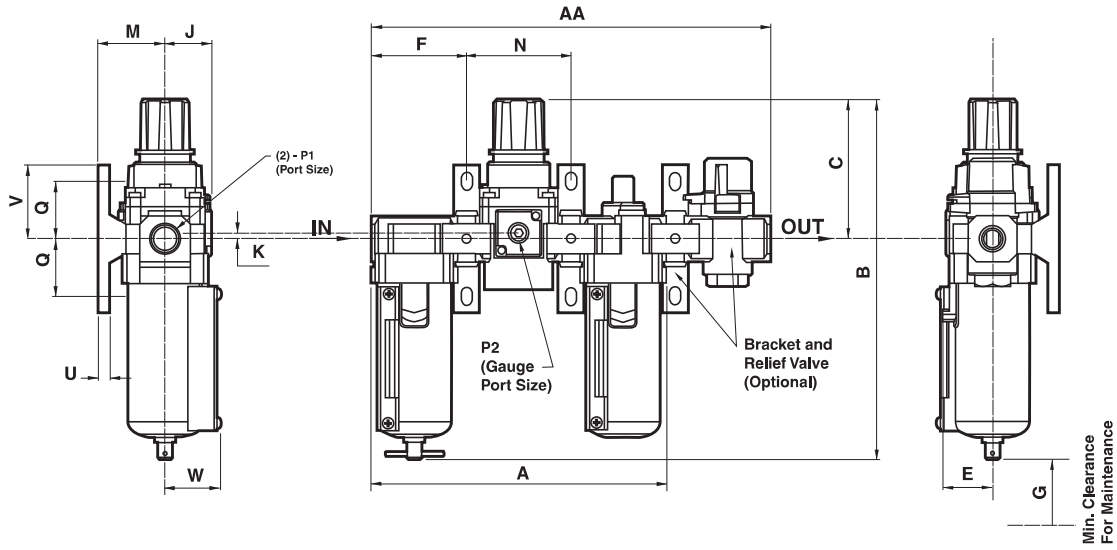

## AC-A

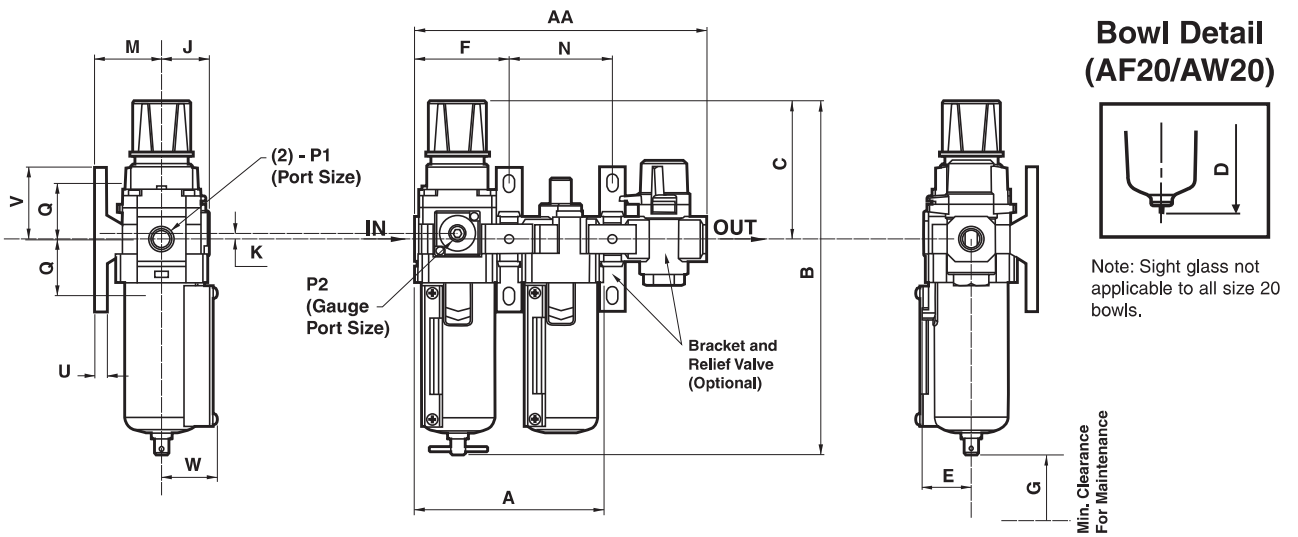

## AC-B

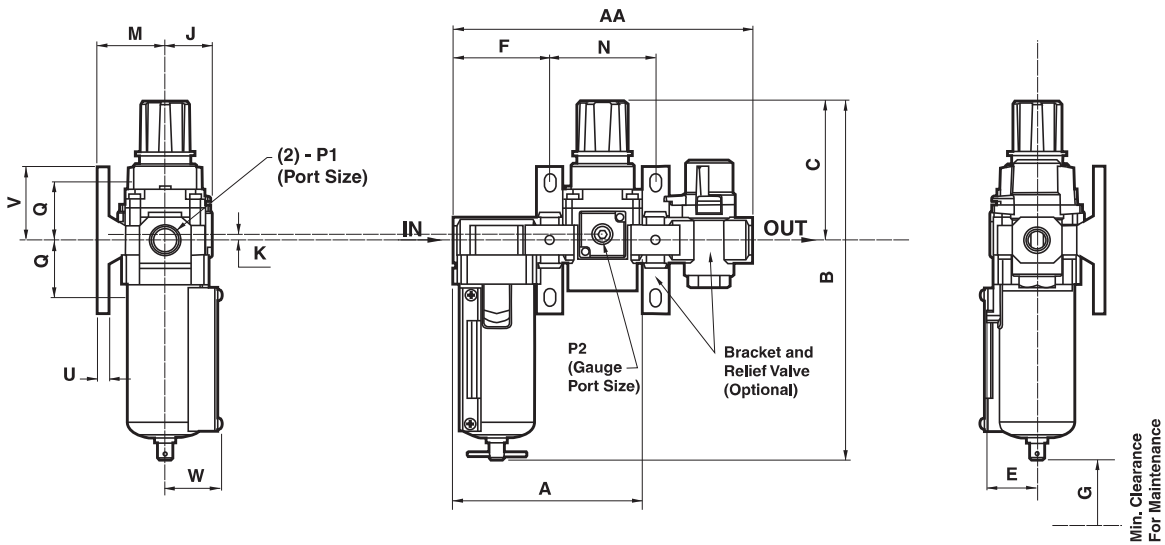

Notes: Filter & Filter Regulator Bowls depict manual drain, see individual sections for details with auto-drain options.

How To Order

**AF 30 - N 03 D - 8 Z - X480**

Filter ●

Body Size ●

Symbol	Size
20	1/8
30	3/8
40	1/2

NPT Threads ●

Port Size ●

Symbol	Port Size	Applicable Body Size
02	1/4	20
03	3/8	30
04	1/2	40

● With External Epoxy Coating, Stainless Fasteners

● Name Plate, Caution Plate On Bowl in psi, °F

● Bowl

Symbol	Description	Applicable Body Size
2	Metal Bowl	20
8	Metal Bowl With Sight Glass	30, 40

● Accessories

Symbol	Description	Applicable Body Size
Nil	None	All
B*	Mounting Bracket	All
C	Float Auto Drain (N.C.)	30, 40
D	Float Auto Drain (N.O.)	30, 40

Note: Other sizes, thread forms, options, etc. may be possible, please contact SMC for availability.

\*Note: Bracket is not assembled and is supplied loose at time of shipment.

Specifications



Body size	20	30	40
Operating specifications	Same as standard - see catalog ES40-42D or NC160A		
Port size	1/4" NPT	3/8" NPT	1/2" NPT
Auto drain port	N/A	1/4" NPT	
Bowl type	Metal	Metal with sight gauge	
Body material	Die cast aluminum		
Bowl material	Die cast aluminum		
Body, Bowl surface treatment	Epoxy resin coating		
Manual drain (AF, AW)	POM		
External screws	Stainless steel 410		
Individual mounting brackets	Epoxy coated steel		
Sight glass hardware	Stainless steel 304		

Dimensions - Refer to drawings on page 5

Standard

Model	Port Size	Dimensions																	Mounting Bracket Kit (Optional)
		A	C	D	E	F	G	H	J	K	L	M	N	P	Q	R	S	T	
AF20	NPT 1/4	40	97	10	40	—	18	30	27	22	5.4	8.4	40	2.3	26	32	M4 X 0.7	—	AF20P-050AS-X480
AF30	NPT 3/8	53	149	14	53	57	16	41	40	23	6.5	8	53	2.3	35	44	M4 X 0.7	34.5	AF30P-050AS-X480
AF40	NPT 1/2	70	185	18	70	73	17	50	54	26	8.5	10.5	70	2.3	47	60	M5 X 0.8	41	AF40P-050AS-X480

Auto Drain

Model	Port Size	Dimensions																	Mounting Bracket Kit (Optional)
		A	C	D	E	F	G	H	J	K	L	M	N	P	Q	R	S	T	
AF30	NPT 3/8	53	158	14	53	57	16	41	40	23	6.5	8	53	2.3	35	44	M4 X 0.7	34.5	AF30P-050AS-X480
AF40	NPT 1/2	70	194	18	70	73	17	50	54	26	8.5	10.5	70	2.3	47	60	M5 X 0.8	41	AF40P-050AS-X480

Standard  
(Manual Drain)

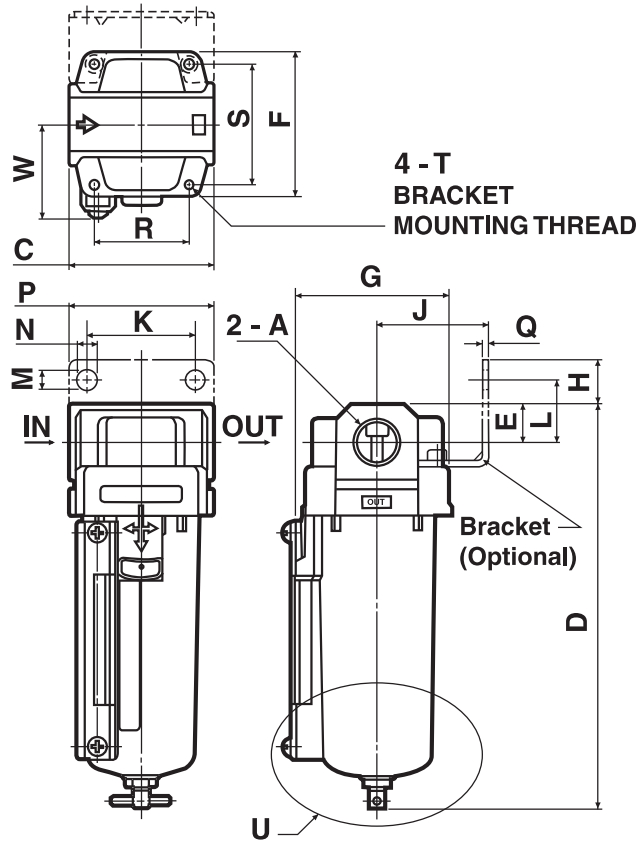

Bowl Detail U  
(AF20)

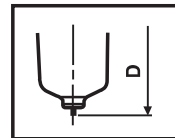

Note: Sight glass not applicable to AF20.

With Auto Drain

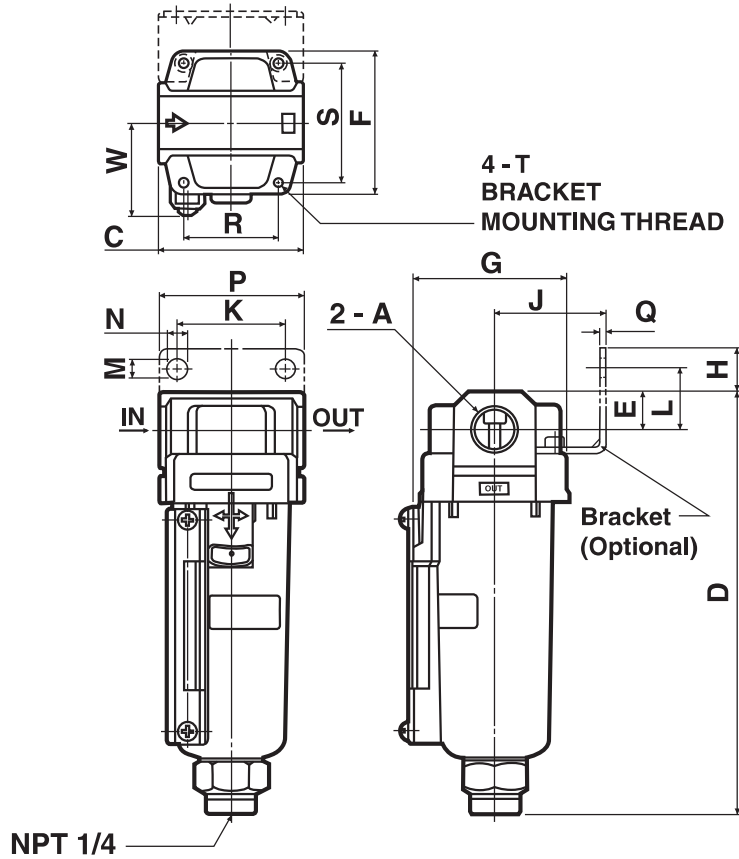

## How To Order

**AW 30 - N 03 D - 8 Z - X48**

Filter - Regulator ●

Body Size ●

Symbol	Size
20	1/8
30	3/8
40	1/2

NPT Threads ●

Port Size ●

Symbol	Port Size	Applicable Body Size
02	1/4	20
03	3/8	30
04	1/2	40

● With External Epoxy Coating, Stainless Fasteners

● Name Plate, Caution Plate On Bowl in psi, °F

● Bowl

Symbol	Description	Applicable Body Size
2	Metal Bowl	20
8	Metal Bowl With Sight Glass	30, 40

● Accessories

Symbol	Description	Applicable Body Size
Nil	None	All
B*	Mounting Bracket	All
C	Float Auto Drain (N.C.)	30, 40
D	Float Auto Drain (N.O.)	30, 40
H*	Panel Mount Nut	All

Note: Other sizes, thread forms, options, etc. may be possible, please contact SMC for availability.

\*Note: Bracket and/or panel mount nut are not assembled and are supplied loose at time of shipment.



### Specifications

Body size	20	30	40
Operating specifications	Same as standard - see catalog ES40-42D or NC160A		
Port size	1/4" NPT	3/8" NPT	1/2" NPT
Auto drain port	N/A	1/4" NPT	
Bowl type	Metal	Metal with sight gauge	
Body material	Die cast aluminum		
Bowl material	Die cast aluminum		
Body, Bowl surface treatment	Epoxy resin coating		
Bonnet	Polyacetal		
Manual drain (AF, AW)	POM		
External screws	Stainless steel 410		
Individual mounting brackets	Epoxy coated steel		
Panel mount nut	POM		
Sight glass hardware	Stainless steel 304		

### Accessories

Model	Mounting Bracket Kit (Optional)	Panel Mounting Nut (Optional)
AW20	AW20P-270AS-X480	AR20P-260S
AW30	AR30P-270AS-X480	AR30P-260S
AW40	AR40P-270AS-X480	AR40P-260S

Dimensions - Refer to drawings on page 7

### Standard

Model	Port Size	Gauge Port	Dimensions																		
			A	C	D	DD	E	F	H	J	K	L	Q	S	T	U	V	W	X	Y	Z
AW20	NPT 1/4	NPT 1/8	40	—	—	70(max.73)	5	157(max.160)	52	30	44	5.4	15.4	34	55	2.3	M28 X 1	30	6	14	28.5
AW30	NPT 3/8	NPT 1/8	53	34.5	30	83(max.86)	3.5	218(max.221)	59	41	46	6.5	8	40	53	2.3	M38 X 1.5	31	7	19	38.5
AW40	NPT 1/2	NPT 1/4	70	41	38	88(max.92)	1.5	255(max.259)	75	50	54	8.5	10.5	54	70	2.3	M42 X 1.5	35.5	7	21	42.5

### Auto Drain

Model	Port Size	Gauge Port	Dimensions																		
			A	C	D	DD	E	F	H	J	K	L	Q	S	T	U	V	W	X	Y	Z
AW30	NPT 3/8	NPT 1/8	53	34.5	30	83(max.86)	3.5	239(max.242)	59	41	46	6.5	8	40	53	2.3	M38 X 1.5	31	7	19	38.5
AW40	NPT 1/2	NPT 1/4	70	41	38	88(max.92)	1.5	276(max.280)	75	50	54	8.5	10.5	54	70	2.3	M42 X 1.5	35.5	7	21	42.5

## Standard (Manual Drain)

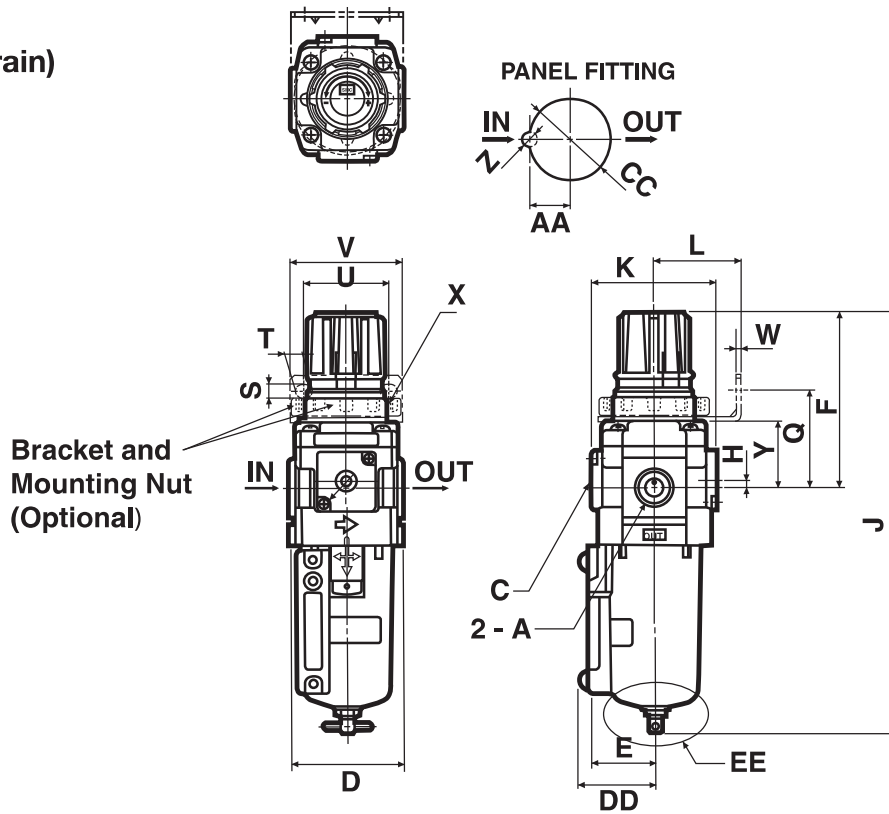

## Bowl Detail EE (AW20)

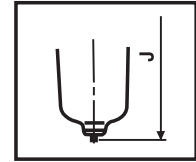

Note: Sight glass not applicable to AW20.

## With Auto Drain

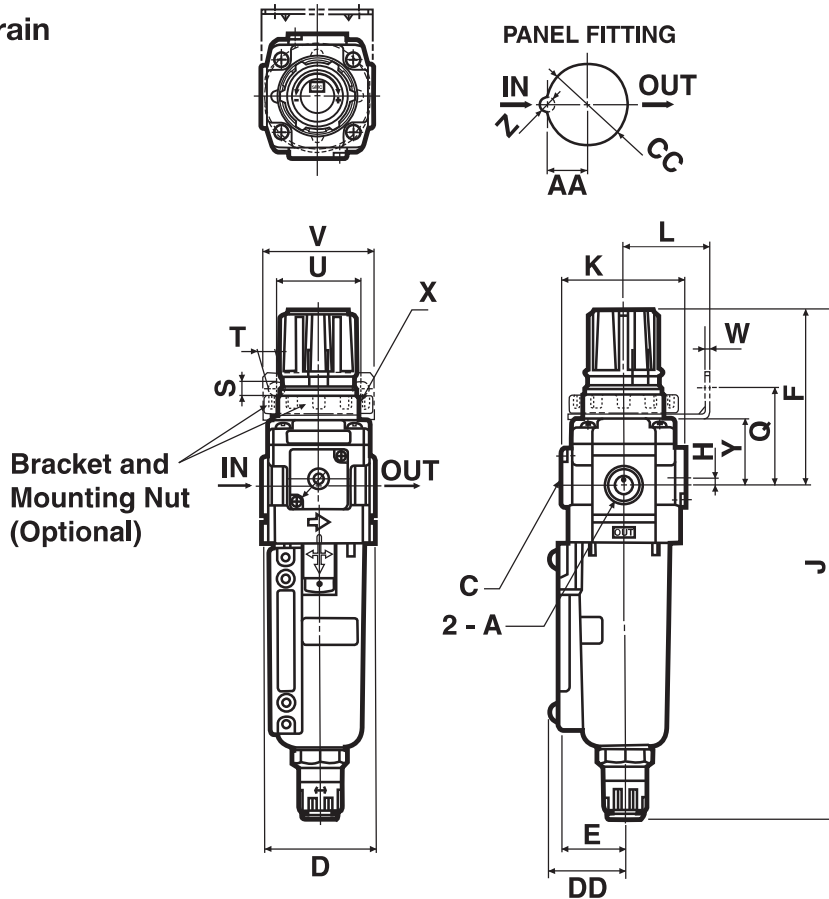

## How To Order

**AR 20 - N 02 B - Y Z - X48**

Regulator

Body Size

Symbol	Size
20	1/8
30	3/8
40	1/2

NPT Threads

Port Size

Symbol	Port Size	Applicable Body Size
02	1/4	20
03	3/8	30
04	1/2	40

With External Epoxy Coating, Stainless Fasteners

Name Plate, Caution Plate On Bowl in psi, °F

Handle Orientation

Symbol	Description
Nil	Handle Down
Y	Handle Up

Accessories

Symbol	Description
Nil	None
B*	Mounting Bracket
H*	Panel Mount Nut

Note: Other sizes, thread forms, options, etc. may be possible, please contact SMC for availability.

\*Note: Bracket and/or panel mount nut are not assembled and are supplied loose at time of shipment.



## Specifications

Body size	20	30	40
Operating specifications	Same as standard - see catalog ES40-42D or NC160A		
Port size	1/4" NPT	3/8" NPT	1/2" NPT
Body material	Die cast aluminum		
Body, Bowl surface treatment	Epoxy resin coating		
Bonnet	Polyacetal		
Individual mounting brackets	Epoxy coated steel		
Panel mount nut	POM		

## Dimensions

Model	Port Size	Gauge Port	Dimensions																		
			A	C	D	E	F	H	J	K	L	M	P	Q	S	T	U	V	W	X	Y
AR20	NPT 1/4	NPT 1/8	40	57	26.5	-2	91(max.94)	30	65	37.5	44	5.4	15.4	34	55	2.3	M28 X 1	6	14	28.5	25
AR30	NPT 3/8	NPT 1/8	53	59	31	3.5	113(max.116)	41	66	37.5	46	6.5	8	40	53	2.3	M38 X 1.5	7	19	38.5	31
AR40	NPT 1/2	NPT 1/4	70	68	36	3.5	124(max.128)	50	74	42.5	54	8.5	10.5	54	70	2.3	M42 X 1.5	7	21	42.5	35.5

## Accessories

Model	Mounting Bracket Kit (Optional)	Panel Mounting Nut (Optional)
AR20	AR20P-270AS-X48	AR20P-260S
AR30	AR30P-270AS-X48	AR30P-260S
AR40	AR40P-270AS-X48	AR40P-260S

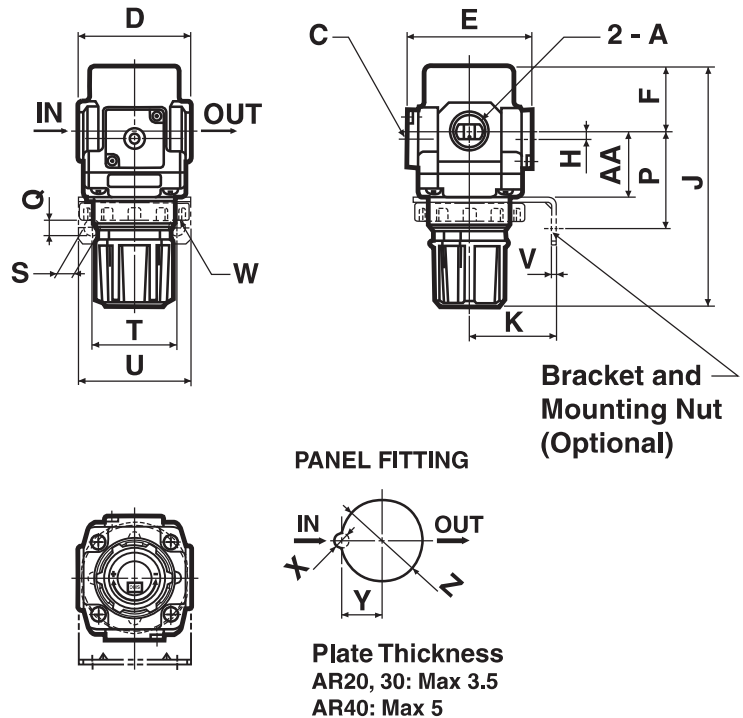

## How To Order

**AL 20 - N 02 B - 2 Z - X480**

Lubricator • Body Size • NPT Threads • Bowl • Accessories • With External Epoxy Coating, Stainless Fasteners • Name Plate, Caution Plate On Bowl in psi, °F

Symbol	Size
20	1/8
30	3/8
40	1/2

Symbol	Port Size	Applicable Body Size
02	1/4	20
03	3/8	30
04	1/2	40

Symbol	Description	Applicable Body Size
2	Metal Bowl	20
8	Metal Bowl With Sight Glass	30, 40

Symbol	Description	Applicable Body Size
Nil	None	All
B*	Mounting Bracket	All

\*Note: Bracket is not assembled and is supplied loose at time of shipment.

Note: Other sizes, thread forms, options, etc. may be possible, please contact SMC for availability.



## Specifications

Body size	20	30	40
Operating specifications	Same as standard - see catalog ES40-42D or NC160A		
Port size	1/4" NPT	3/8" NPT	1/2" NPT
Bowl type	Metal	Metal with sight gauge	
Body material	Die cast zinc	Die cast aluminum	
Bowl material	Die cast aluminum		
Body, Bowl surface treatment	Epoxy resin coating		
Individual mounting brackets	Epoxy coated steel		
Fill plug	Stainless steel 304		
Sight dome	Polycarbonate		
Sight glass hardware	Stainless steel 304		

## Dimensions

mm

Model	Port Size	Dimensions																	Mounting Bracket Kit (Optional)
		A	C	D	E	F	G	H	J	K	L	M	N	P	Q	R	S	T	
AL20	NPT 1/4	40	121	36	40	—	28	30	27	22	5.4	8.4	40	2.3	26	32	M4 X 0.7	—	AF20P-050AS-X480
AL30	NPT 3/8	53	162	38	53	57	30	41	40	23	6.5	8	53	2.3	35	44	M4 X 0.7	34.5	AF30P-050AS-X480
AL40	NPT 1/2	70	196	40	70	73	35	50	54	26	8.5	10.5	70	2.3	47	60	M5 X 0.8	41	AF40P-050AS-X480

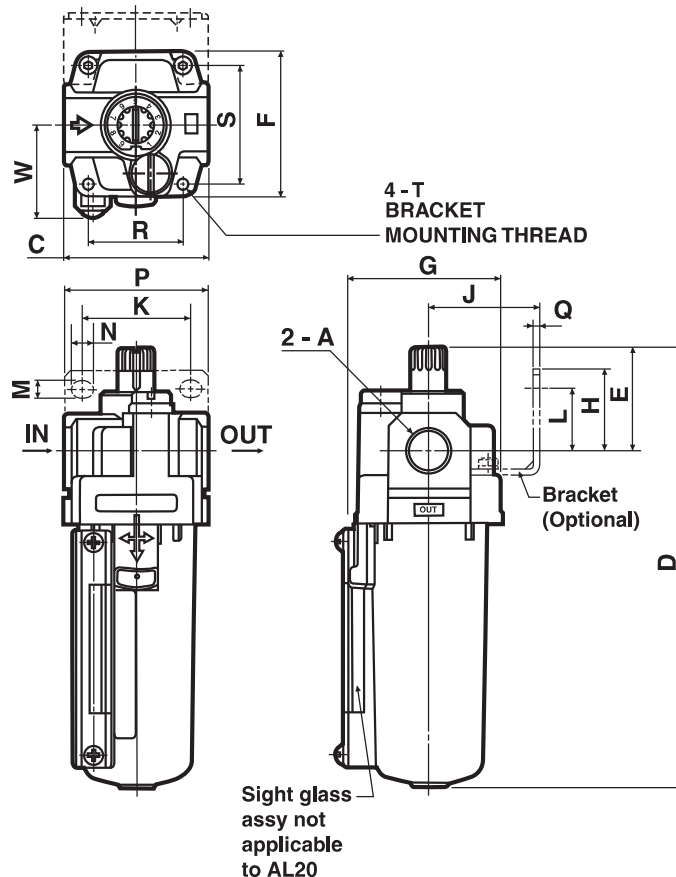

## Residual Pressure Relief 3 Port Valve (V)

With the use of a 3 port valve for residual pressure release, pressure left in the line can be easily exhausted.



JIS Symbol

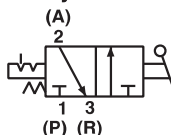

Model	Port Size		Effective area mm <sup>2</sup> (Cv)	
	IN, OUT	EXH	IN to OUT	OUT to EXH
VHS20	1/4	1/8	14 (0.76)	16 (0.87)
VHS30	3/8	1/4	31 (1.68)	29 (1.57)
VHS40	1/2	3/8	55 (2.98)	42 (2.28)

Paint color (Standard) Handle: Red Body: Platinum silver  
Use an air filter on the IN side for operating protection.

### How To Order

**VHS 30 - N 02 - Z - X513**

- Residual Pressure Relief 3 Port Valve** (VHS)
- Body Size** (30)
- Thread Type** (N)
- Body Size** (02)
- With External Epoxy Coating, Stainless Fasteners** (Z)
- Name Plate In Imperial Units (PSI, °F)** (X513)

Symbol	Applicable Model
20	AC21
30	AC31
40	AC41

Symbol	Port Size	Body Size		
		20	30	40
02	1/4	●		
03	3/8		●	
04	1/2			●

Note: Other sizes, thread forms, options, etc. may be possible, please contact SMC for availability.

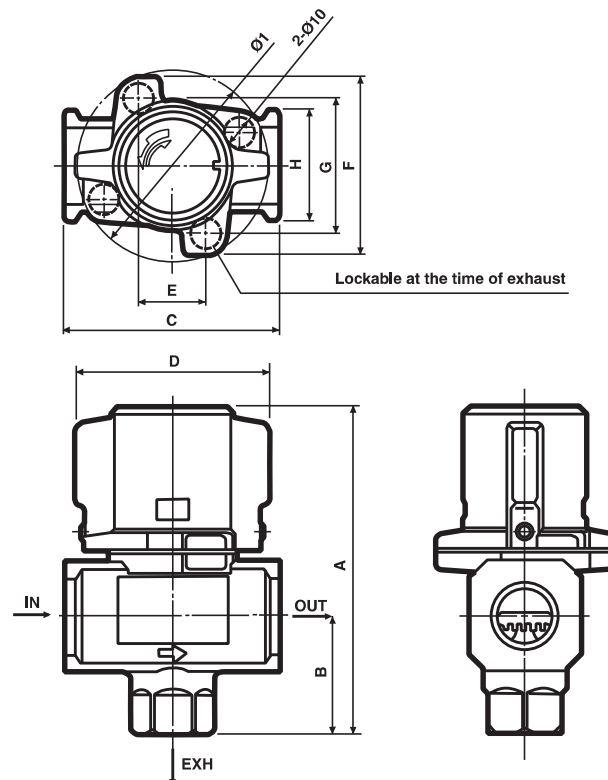

Dimensions

Model	A	B	C	D	E	F	G	H	I
VHS20	59	20	40	34	—	45	33	28	45
VHS30	78	29	53	46	—	55	42	30	55
VHS40	107	39	70	63	22	58	44	36	63

### Caution

- If a stop valve or a silencer is connected to the exhaust port of VHS20/30, the effective sectional area should be larger than the figure indicated in the following table, to prevent malfunction caused by back pressure. (This is not applicable to VHS40)

Model	Effective area (mm <sup>2</sup> )
VHS20	5
VHS30	5

- If unit is to be used in a washdown application, avoid directing fluid into the exhaust port.

## Spacer

Epoxy Coated Aluminum,  
Stainless Screws,  
NBR Seals

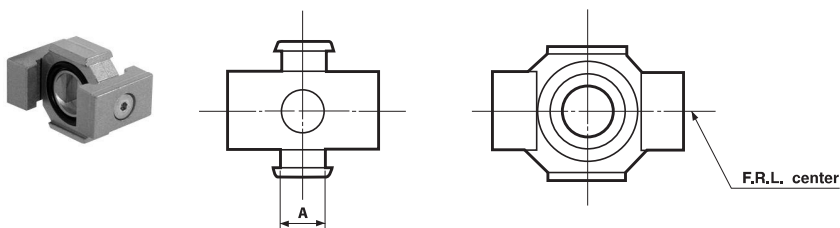

### Dimensions

Model	A
Y20-T4	10
Y30-T4	11
Y40-T4	14

## Interface With T Bracket

Epoxy Coated Aluminum, Stainless Screws,  
NBR Seals

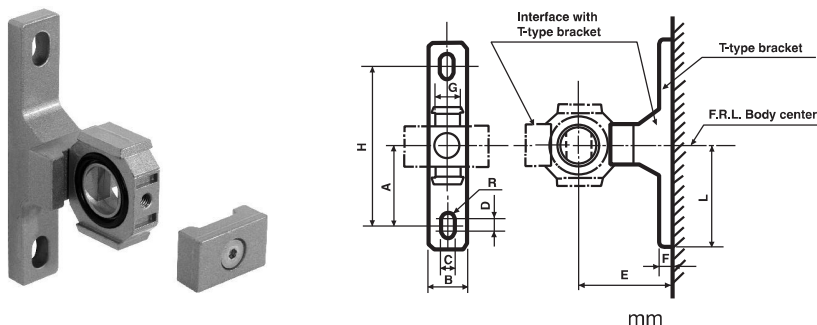

### Dimensions

Interface With T Bracket	A	B	C	D	E	F	G	H	R	L	Applicable Models
Y20T-T4	24	15	5.5	3	30	5	10	48	2.75	33	AC21*-X2217
Y30T-T4	35	16	7	4	41	7	11	70	3.5	45	AC31*-X2217
Y40T-T4	40	22	9	4	50	7	14	80	4.5	50	AC41*-X2217

## Other Available Air Line Products with Epoxy Coating/Stainless Hardware

Series	Description	Option Code
(N)AV	Soft Start Valve	X480
AMG	Water Removal Filter	X229
AR20-60	Regulator with Stainless T-handle, aluminum bonnet for UV resistance	X480
AVL	Soft Start Valve with Pilot Lock-Out	X480
AW20-40	Filter-Regulator with Stainless T-handle, aluminum bonnet for UV resistance	X480
E*00	Piping Adapter	X480
Y*10	T Interface	X480
Y*4	Cross Interface	T3

Please contact SMC for ordering information

# Salt Spray Test Results (for reference)

## 1. Test Conditions

**1) Method:** In compliance with ASTM B117-07a (JIS Z 2371), leave parts in a salt spray test chamber, and compare rust generation.

**2) Conditions:** Temperature: 95°F (35°C) Salt Water Concentration: 5%

**3) Time:** 1000 hours [Frequency: 0hr, 24hrs, 48hrs, 72hrs, 96hrs, 168hrs, 240hrs, 480hrs, 720hrs, 1000hrs]

**4) Samples:** Parts for AF and AW30 (See Figure 1.)

- Part descriptions: 4 parts (1) Body (2) Drain cock (3) Small screw for level gauge (4) Bonnet screw
- Types: 2 Types A) Standard B) Special X480 (Coated with epoxy resin [External metal parts are made of SUS])
- Refer to Table 1 for part materials and treatments. \*Quantity; 2 pieces for each

## 2. Test Results Table 1 Salt spray resistance test results

No.	Description	Type	Material & Treatment	Results
1	Body	A Standard	Material: Die Cast Aluminum Treatment: Platinum Coating	Rusted in 480hrs Part of coating swelled
		B Special X480	Material: Die Cast Aluminum Treatment: Platinum & Epoxy Coating	Not rusted in 1000hrs Part of coating swelled
2	Drain cock	A Standard	Material: Die Cast Aluminum Treatment: Zinc Chromate	Rusted in 24hrs
		B Special X480	Material: SUS	Not rusted in 1000hrs
3	Cross recessed round head screw for metal bowl with level gauge	A Standard	Material: Steel Treatment: Nickel Plating	Rusted in 24hrs
		B Special X480	Material: SUS	Not rusted in 1000hrs
4	Self-tapping screw for AR and AW bonnet	A Standard	Material: Steel Treatment: Zinc Chromate	Rusted in 24hrs
		B Special X480	Material: SUS	Not rusted in 1000hrs

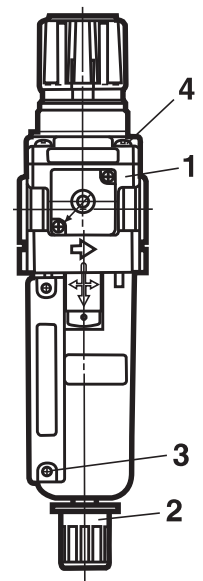
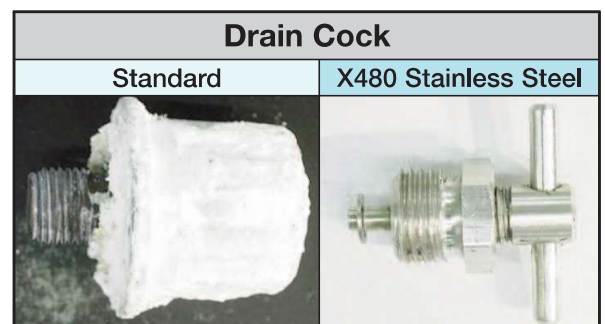
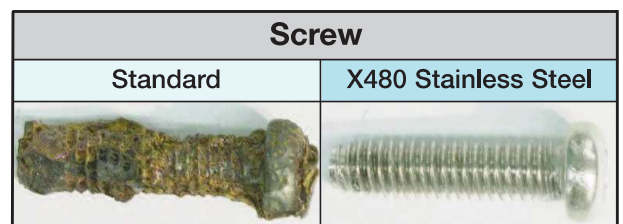
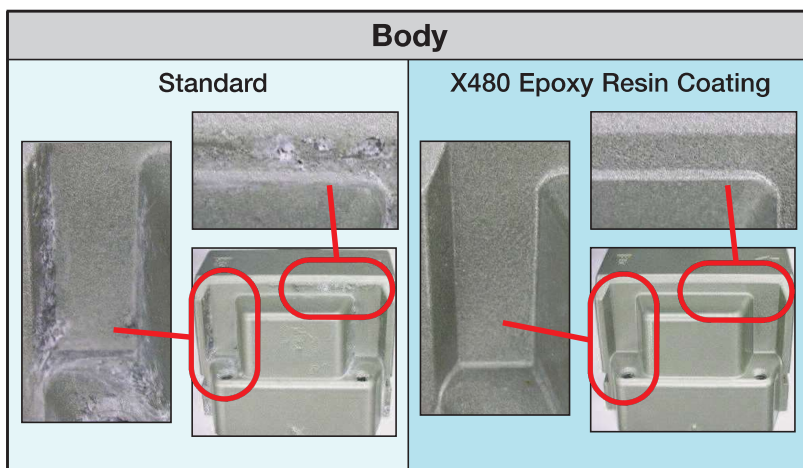

Figure 1



**Caution!** To ensure the safest possible operation of this product, please be sure to read thoroughly the "Safety Instructions" in our "Best Pneumatics" catalog before use.