

# Inline filters with filter element according to DIN 24550

Type 245LEN0040 to 0400; 245LE0130, 0150

**RE 51421**

Edition: 2014-08

Replaces: 07.11



- ▶ Size according to **DIN 24550**: 0040 to 0400
- ▶ additional sizes: 0130, 0150
- ▶ Nominal pressure 250 bar [3628 psi]
- ▶ Connection up to G1 1/2; SAE 1 1/2; SAE 24
- ▶ Operating temperature: -10 °C to +100 °C [+14 °F to +212 °F]

## Features

Inline filters are used in hydraulic systems for separating solid materials from fluids and lubricating oils. They are intended for attachment in pipelines.

They distinguish themselves by the following:

- ▶ Filters for inline installation
- ▶ Special highly efficient filter materials
- ▶ Filtration of very fine particles and high dirt holding capacity across a broad pressure differential range
- ▶ High collapse resistance of the filter elements
- ▶ By default equipped with mechanical optical maintenance indicator with memory function
- ▶ Various, optional electronic switching elements, modular design
- ▶ Optional bypass valve integrated in the filter housing
- ▶ High filtration performance due to the tangential cyclone-effect flow path

## Contents

Features	1
Ordering code filter	2, 3
Preferred types	4
Ordering code accessories	5
Symbols	6
Function, section	7
Technical data	8, 9
Compatibility with permitted hydraulic fluids	9
Characteristic curves	10 ... 13
Dimensions	14 ... 15
Maintenance indicator	16
Ordering code spare parts	17 ... 19
Assembly, commissioning, maintenance	20
Tightening torques	21
Directives and standardization	21, 22

## Ordering code filter

01	02	03	04	05	06	07	08	09		
245LE	N		-			-	-		-	

### Series

01	Inline filter 250 bar [3628 psi]	245LE
----	----------------------------------	-------

### Filter element

02	With filter element according to <b>DIN 24550</b>	N
----	---	---

### Size

03	LEN...	0040 0063 0100 0160 0250 0400
	LE...	0130 0150

### Filter rating in $\mu\text{m}$

04	<b>Absolute</b> (ISO 16889; $\beta_x(c) \geq 200$ )	Glass fiber material, not cleanable	H3XL H6XL H10XL H20XL
	<b>Nominal</b>	Stainless steel wire mesh, cleanable	G10 G25 G40 G60 G100

### Pressure differential

05	Max. admissible pressure differential of the filter element 30 bar [435 psi] – Filter <b>with</b> bypass valve	A00
	Max. admissible pressure differential of the filter element 330 bar [4786 psi] – Filter <b>without</b> bypass valve	B00

### Maintenance indicator

06	Maintenance indicator, mech./optical, switching pressure 2.2 bar [31.9 psi] – bypass cracking pressure 3.5 bar [51 psi]	V2.2
	Maintenance indicator, mech./optical, switching pressure 5.0 bar [72.5 psi] – bypass cracking pressure 7.0 bar [101 psi]	V5.0

### Seal

07	NBR seal	M
	FKM seal	V

**Ordering code filter**

01	02	03	04	05	06	07	08	09
245LE	N		-		-	-	-	

**Connection**

08	<b>Frame size</b>		<b>0040</b>	<b>0063-0100</b>	<b>0130-0150</b>	<b>0160-0400</b>		
	<b>Connection</b>							
	G1/2	Pipe thread according to ISO 228	●	X			<b>R2</b>	
	G3/4		X	X			<b>R3</b>	
	G1		X	●	X		<b>R4</b>	
	G1 1/4				●	X	<b>R5</b>	
	G1 1/2				X	●	<b>R6</b>	
	SAE 1 1/2"	SAE flange 6,000 psi				X	<b>S6</b>	
	SAE 10	Pipe thread according to SAE J1926	X				<b>U3</b>	
	SAE 12			X			<b>U4</b>	
	SAE 20				X		<b>U5</b>	
	SAE 24					X	<b>U6</b>	
			● Standard connection					
			X Alternative connection					

**Supplementary information**

09	Manufacturer's inspection certificate M according to DIN 55350 T18	<b>Z1</b>
----	--	-----------

**Order example:**

**245LEN0100-H10XLA00-V5,0-M-R4**

**Further versions (filter materials, connections,...) are available on request.**

## Preferred types

245LE(N) preferred types, NBR seal, flow specifications for 30 mm<sup>2</sup>/s [143 SUS]

### Inline filter with bypass, filter rating 3 µm

Type	Flow in l/min [gpm] at $\Delta p = 1.5 \text{ bar}$ [21.75 psi] <sup>1)</sup>	Material no. Filter				Material no. Replacement element
		..R2	R928030024	..U3	R928030216	
245LEN0040-H3XLA00-V5,0-M-..	29 [6.1]	..R2	R928030024	..U3	R928030216	R928006645
245LEN0063-H3XLA00-V5,0-M-..	44 [7.9]	..R4	R928030025	..U4	R928030217	R928006699
245LEN0100-H3XLA00-V5,0-M-..	61 [11.6]	..R4	R928030026	..U4	R928030218	R928006753
245LE0130-H3XLA00-V5,0-M-..	101 [19.5]	..R5	R928030027	..U5	R928030219	R928022274
245LE0150-H3XLA00-V5,0-M-..	123 [23.5]	..R5	R928030028	..U5	R928030220	R928022283
245LEN0160-H3XLA00-V5,0-M-..	184 [34.9]	..R6	R928030029	..U6	R928030221	R928006807
245LEN0250-H3XLA00-V5,0-M-..	261 [50.2]	..R6	R928030030	..U6	R928030222	R928006861
245LEN0400-H3XLA00-V5,0-M-..	330 [66.0]	..R6	R928030031	..U6	R928030223	R928006915

### Inline filter with bypass, filter rating 6 µm

Type	Flow in l/min [gpm] at $\Delta p = 1.5 \text{ bar}$ [21.75 psi] <sup>1)</sup>	Material no. Filter				Material no. Replacement element
		..R2	R928030280	..U3	R928030472	
245LEN0040-H6XLA00-V5,0-M-..	48 [12.7]	..R2	R928030280	..U3	R928030472	R928006646
245LEN0063-H6XLA00-V5,0-M-..	78 [20.6]	..R4	R928030281	..U4	R928030473	R928006700
245LEN0100-H6XLA00-V5,0-M-..	82 [21.7]	..R4	R928030282	..U4	R928030474	R928006754
245LE0130-H6XLA00-V5,0-M-..	152 [40.2]	..R5	R928030283	..U5	R928030475	R928022275
245LE0150-H6XLA00-V5,0-M-..	170 [45.0]	..R5	R928030284	..U5	R928030476	R928022284
245LEN0160-H6XLA00-V5,0-M-..	245 [64.7]	..R6	R928030285	..U6	R928030477	R928006808
245LEN0250-H6XLA00-V5,0-M-..	310 [81.9]	..R6	R928030286	..U6	R928030478	R928006862
245LEN0400-H6XLA00-V5,0-M-..	400 [105.7]	..R6	R928030287	..U6	R928030479	R928006916

### Inline filter with bypass, filter rating 10 µm

Type	Flow in l/min [gpm] at $\Delta p = 1.5 \text{ bar}$ [21.75 psi] <sup>1)</sup>	Material no. Filter				Material no. Replacement element
		..R2	R928030536	..U3	R928030728	
245LEN0040-H10XLA00-V5,0-M-..	58 [15.3]	..R2	R928030536	..U3	R928030728	R928006647
245LEN0063-H10XLA00-V5,0-M-..	98 [18.2]	..R4	R928030537	..U4	R928030729	R928006701
245LEN0100-H10XLA00-V5,0-M-..	84 [22.2]	..R4	R928030538	..U4	R928030730	R928006755
245LE0130-H10XLA00-V5,0-M-..	172 [45.4]	..R5	R928030539	..U5	R928030731	R928022276
245LE0150-H10XLA00-V5,0-M-..	196 [51.8]	..R5	R928030540	..U5	R928030732	R928022285
245LEN0160-H10XLA00-V5,0-M-..	281 [74.2]	..R6	R928030541	..U6	R928030733	R928006809
245LEN0250-H10XLA00-V5,0-M-..	330 [87.2]	..R6	R928030542	..U6	R928030734	R928006863
245LEN0400-H10XLA00-V5,0-M-..	420 [111.0]	..R6	R928030543	..U6	R928030735	R928006917

<sup>1)</sup> An appropriate differential pressure via the filter and measuring device according to ISO 3968. The differential pressure measured on the maintenance indicator is lower.

**Ordering code accessories**  
(dimensions in mm [inch])

**Electronic switching element for maintenance indicators**

01	02	03
WE	-	-

**Maintenance indicator**

01	Electronic switching element	<b>WE</b>
----	------------------------------	-----------

**Type of signal**

02	1 switching point	<b>1SP</b>
	2 switching points, 3 LED	<b>2SP</b>
	2 switching points, 3 LED and signal suppression up to 30 °C [86 °F]	<b>2SPSU</b>

**Connector**

03	Round plug-in connection M12 x 1, 4-pole	<b>M12 x 1</b>
	Rectangular plug-in connection, 2-pole, design A according to EN-175301-803	<b>EN175301-803</b>

**Material numbers of the electronic switching elements**

Material no.	Type	Signal	Switching points	Connector	LED	
<b>R928028409</b>	WE-1SP-M12 x 1	Changeover	1	M12 x 1	without	
<b>R928028410</b>	WE-2SP-M12 x 1	Normally open (at 75%) / normally closed contact (at 100%)	2		EN 175301-803	3 pieces
<b>R928028411</b>	WE-2SPSU-M12 x 1					
<b>R928036318</b>	WE-1SP-EN175301-803	Normally closed contact	1			without

**Mating connectors**

for electronic switching element with round plug-in connection M12 x 1

Mating connector suitable for K24 4-pole, M12 x 1 with screw connection, cable gland Pg9.

**Material no. R900031155**

Mating connector suitable for K24-3m 4-pole, M12 x 1 with potted-in PVC cable, 3 m long.

Line cross-section: 4 x 0.34 mm<sup>2</sup>

Core marking:     **1** brown           **2** white  
                          **3** blue               **4** black

**Material no. R900064381**

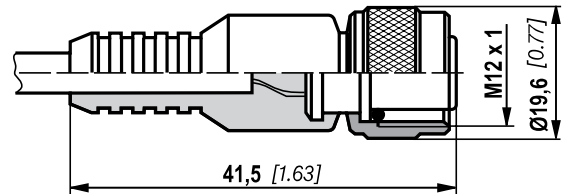
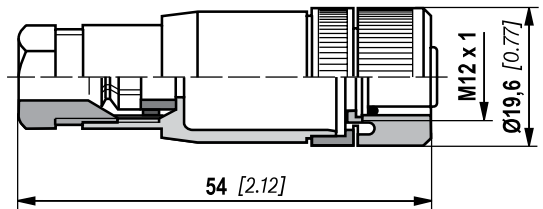

For more round plug-in connections and technical data refer to data sheet 08006.

**Order example:**

Inline filter with mechanical optical maintenance indicator for  $p_{nom.} = 250 \text{ bar [3628 psi]}$  with bypass valve, size 0100, with filter element 10  $\mu\text{m}$  and electronic switching element M12x1 with 1 switching point for hydraulic fluid mineral oil HLP according to DIN 51524.

**Filter with mech. optical maintenance indicator:** 245LEN0100-H10XLA00-V5,0-M-R4

**Material no. R928030538**

**Switching element:** WE-1SP-M12 x 1

**Material no. R928028409**

**Mating connector:** Mating connector suitable for K24 4-pole, M12 x 1 with screw connection, cable gland Pg9.

**Material no. R900031155**

## Symbols

**Inline filter** with bypass and mechanical indicator

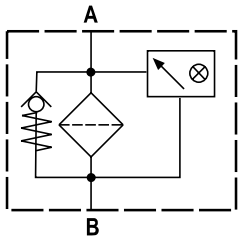

**Inline filter** without bypass and with mechanical indicator

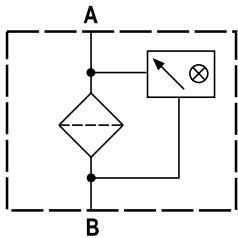

**Electronic switching element for maintenance indicator**

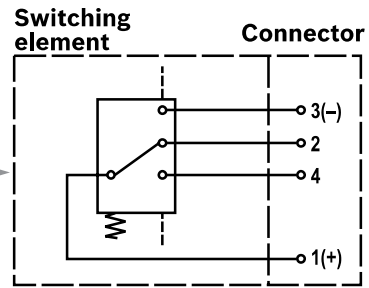

**WE-1SP-M12 x 1**

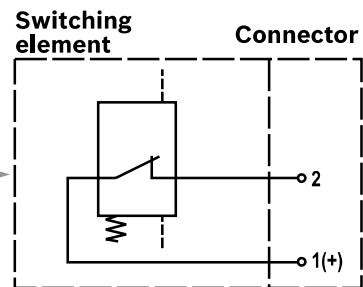

**WE-1SP-EN175301-803**

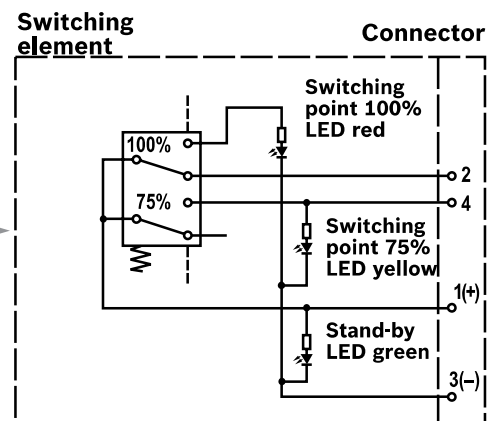

**WE-2SP-M12 x 1**

Circuit diagram drawn in plugged condition (operating state)

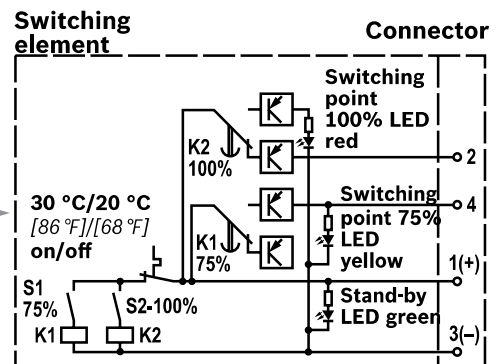

**WE-2SPSU-M12 x 1**

Circuit diagram drawn in plugged condition at temperature > 30 °C [86 °F] (operating condition)

## Function, section

The 245LE(N) inline filter is suitable for inline installation. It basically consists of filter head (1), a screwable filter bowl (2), filter element (3) as well as mechanical optical maintenance indicator (4). In case of filters with low-pressure-differential-stable filter elements (= code letter pressure differential A), there is an assembled bypass valve (5) as standard.

Via the inlet, the fluid reaches the filter element (3) where it is cleaned. The dirt particles filtered out collect in the filter element (3). Via the outlet, the filtered fluid enters the hydraulic circuit.

The filter housing and all connection elements are designed so that pressure peaks - as they may e.g. occur in case of abrupt opening of large control valves due to the accelerated fluid quantity - can be securely absorbed. As of size 0160, the standard equipment comprises a drain screw (7).

By default, the filter is equipped with mechanical optical maintenance indicator (4). The electronic switching element (8) which has to be ordered separately is attached to the mechanical optical maintenance indicator (4) and held by means of a locking ring.

The electronic switching elements with 1 or 2 switching points are connected via a mating connector according to IEC-60947-5-2 or via a cable connection according to EN17301-803.

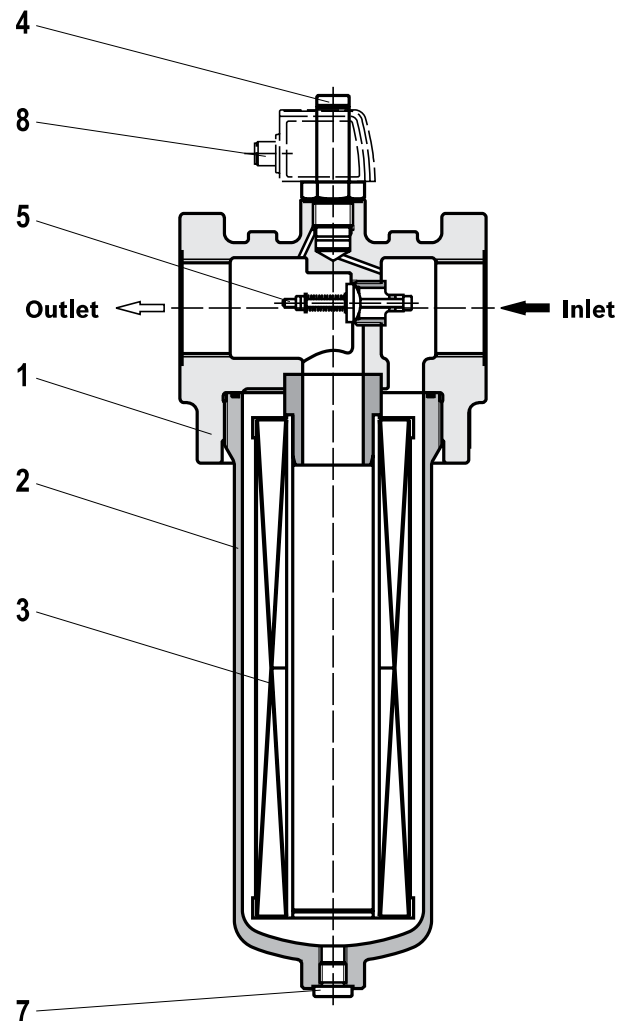

### WARNING!

- ▶ If the maintenance indicator is not observed while the element is exchanged, the bypass valve will open if the pressure differential increases. This means that part of the volume flow enters unfiltered into the clean side of the filter. Effective filtration is therefore no longer guaranteed.

**Technical data**

(For applications outside these parameters, please consult us!)

<b>General</b>						
Installation position		vertical				
Ambient temperature range		°C [°F]	-10 ... +65 [+14 ... +149]; (short periods down to -30 [-22])			
Storage conditions	- NBR seal	°C [°F]	40 ... +65 [-40 ... +149]; max. relative air humidity 65%			
	- FKM seal	°C [°F]	-20 ... +65 [-4 ... +149]; max. relative air humidity 65%			
Weight	- Filter	Size	<b>0040</b>	<b>0063</b>	<b>0100</b>	<b>0130</b>
		kg [lbs]	3.2 [7.10]	3.8 [8.40]	4.2 [9.30]	6.95 [15.30]
		Size	<b>0150</b>	<b>0160</b>	<b>0250</b>	<b>0400</b>
		kg [lbs]	7.25 [16]	11.5 [25.40]	12.2 [26.90]	13.8 [30.40]
	- Filter bowl	Size	<b>0040</b>	<b>0063</b>	<b>0100</b>	<b>0130</b>
		kg [lbs]	0.57 [1.26]	1.03 [2.27]	1.44 [3.17]	1.93 [4.25]
		Size	<b>0150</b>	<b>0160</b>	<b>0250</b>	<b>0400</b>
		kg [lbs]	2.27 [5.00]	2.49 [5.49]	3.33 [7.34]	4.72 [10.41]
Volume	Size	<b>0040</b>	<b>0063</b>	<b>0100</b>	<b>0130</b>	
		l [US gal]	0.21 [0.06]	0.38 [0.10]	0.53 [0.14]	0.76 [0.20]
	Size	<b>0150</b>	<b>0160</b>	<b>0250</b>	<b>0400</b>	
		l [US gal]	0.96 [0.25]	1.13 [0.30]	1.6 [0.42]	2.4 [0.63]
Material	- Filter head	GGG				
	- Filter bowl	Steel				
	- Bypass valve	Aluminum / steel / POM				
	- Seals	NBR or FKM				
	- Optical maintenance indicator	Brass				
	- Electronic switching element	Plastic PA6				

<b>Hydraulic</b>			
Maximum operating pressure	bar [psi]	250 [3628]	
Hydraulic fluid temperature range	°C [°F]	-10 ... +100 [+14 ... +212]	
Minimum conductivity of the medium	pS/m	300	
Fatigue strength according to ISO 10771	Load cycles	> 10 <sup>6</sup> with max. operating pressure	
Type of pressure measurement of the maintenance indicator	Pressure differential		
Assignment: Response pressure of the maintenance indicator / cracking pressure of the bypass valve		Response pressure of the maintenance indicator	Cracking pressure of the bypass valve
	bar [psi]	2.2 ± 0.3 [31.9 ± 4.4]	3.5 ± 0.35 [50.8 ± 5.1]
	bar [psi]	5.0 ± 0.5 [72.5 ± 7.3]	7.0 ± 0.5 [101.5 ± 7.3]
Filtration direction	From the outside to the inside		

### Technical data

(For applications outside these parameters, please consult us!)

Electric (electronic switching element)				
Electrical connection	Round plug-in connection M12 x 1, 4-pole			Standard connection EN 175301-803
	Version	WE-1SP-M12 x 1	WE-2SP-M12 x 1	WE-2SPSU-M12 x 1
Contact load, direct voltage	$A_{max.}$	1		
Voltage range	$V_{max.}$	150 (AC/DC)	10 ... 30 (DC)	250 (AC)/200 (DC)
Max. switching power with resistive load	W	20		70
Switching type	- 75% signal	-	Normally open contact	
	- 100% signal	Changeover	Normally closed contact	
	- 2SPSU			Signal interconnection at 30 °C [86 °F], return switching at 20 °C [68 °F]
Display via LEDs in the electronic switching element 2SP...		Stand-by (LED green); 75% switching point (LED yellow) 100% switching point (LED red)		
Protection class according to EN 60529	IP	67		65
Ambient temperature range	°C [°F]	-25 ... +85 [-13 ... +185]		
For direct voltage above 24 V, spark extinguishing is to be provided for protecting the switching contacts.				
Weight	- electronic switching element	kg [lbs]	0.1 [0.22]	

Filter element				
Glass fiber material H.XL		Single-use element on the basis of inorganic fiber		
		Filtration ratio according to ISO 16889 up to $\Delta p = 5 \text{ bar [72.5 psi]}$	Achievable oil cleanliness according to ISO 4406 [SAE-AS 4059]	
Particle separation	H20XL	$\beta_{20(c)} \geq 200$	19/16/12 ... 22/17/14	
	H10XL	$\beta_{10(c)} \geq 200$	17/14/10 ... 21/16/13	
	H6XL	$\beta_{6(c)} \geq 200$	15/12/10 ... 19/14/11	
	H3XL	$\beta_{5(c)} \geq 200$	13/10/8 ... 17/13/10	
Admissible pressure differential	- A00	bar [psi]	30 [435]	
	- B00	bar [psi]	330 [4785]	

### Compatibility with permitted hydraulic fluids

Hydraulic fluid	Classification	Suitable sealing materials	Standards	
Mineral oil	HLP	NBR	DIN 51524	
Biodegradable	- insoluble in water	HETG	VDMA 24568	
		HEES		
Flame-resistant	- soluble in water	HEPG	VDMA 24568	
	- water-free	HFDU, HFDR	VDMA 24317	
	- containing water	HFAS	NBR	DIN 24320
		HFAE	NBR	
HFC		NBR		
			VDMA 24317	



#### Important information on hydraulic fluids!

- For more information and data on the use of other hydraulic fluids, please refer to data sheet 90220 or contact us!
- **Flame-resistant – containing water:** Due to possible chemical reactions with materials or surface coatings of machine and system components, the service life with these hydraulic fluids may be less than expected.

Filter materials made of filter paper (P) may not be used, filter elements with glass fiber material have to be used instead.

- **Biodegradable:** If filter materials made of filter paper are used, the filter life may be shorter than expected due to material incompatibility and swelling.

**Characteristic curves**

(measured with mineral oil HLP46 according to ISO 3968)

Spec. weight: < 0.9 kg/dm<sup>3</sup> Δp-Q-characteristic curves for complete filters recommended initial Δp for design = 1.5 bar [21.75 psi]

A proper filter design is made possible by our online “Bosch Rexroth FilterSelect” design software.

Oil viscosity:   
 ——— 140 mm<sup>2</sup>/s [649 SUS]   
 - - - 68 mm<sup>2</sup>/s [315 SUS]   
 - - - 30 mm<sup>2</sup>/s [143 SUS]

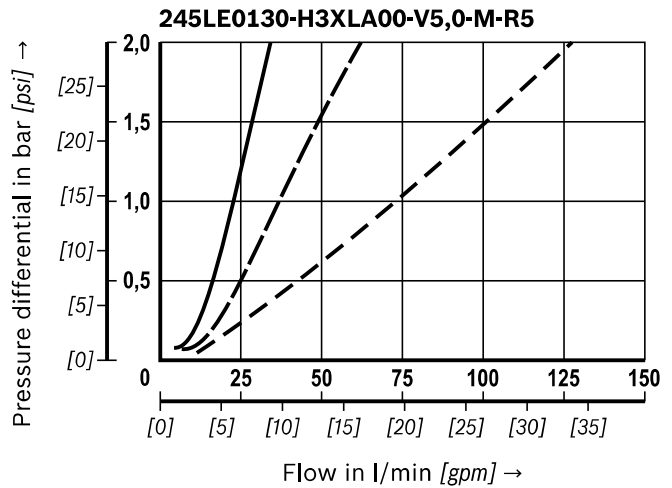
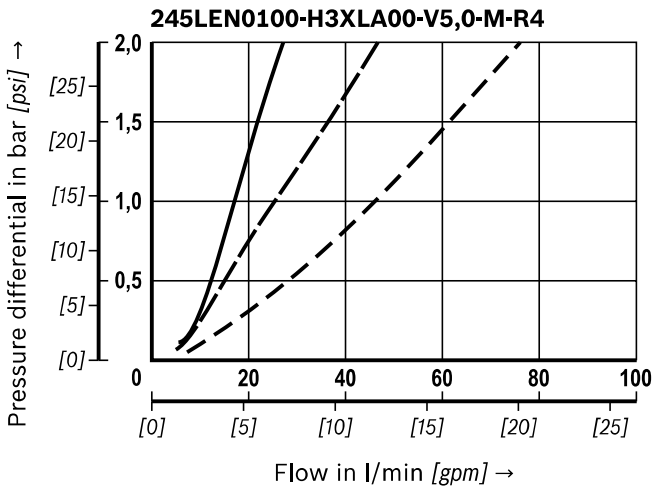
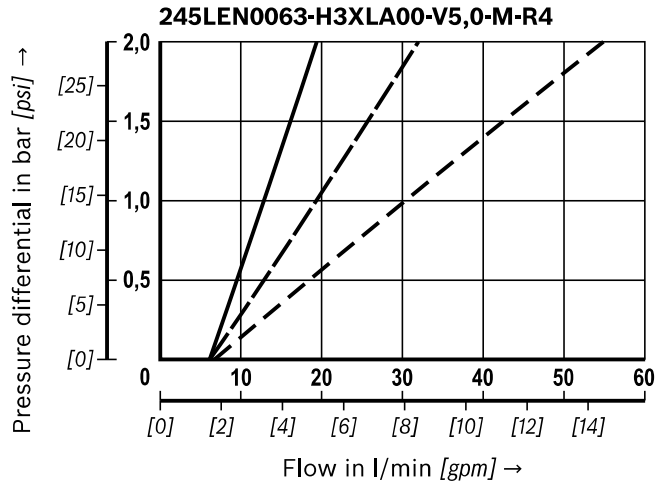
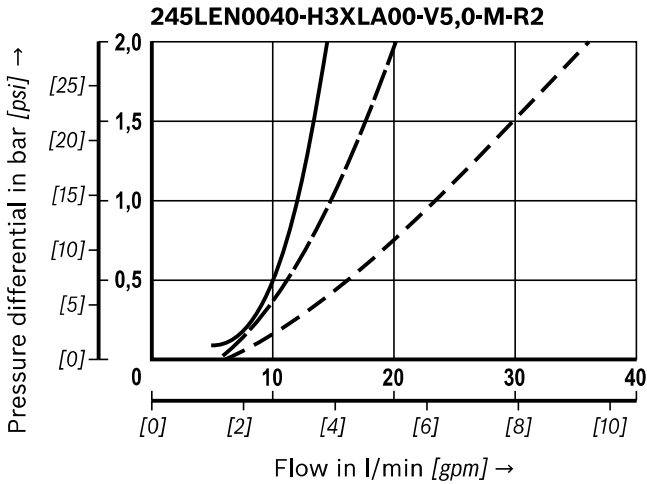

**Characteristic curves**  
(measured with mineral oil HLP46 according to ISO 3968)

**H3XL**

Spec. weight: < 0.9 kg/dm<sup>3</sup> Δp-Q-characteristic curves for complete filters recommended initial Δp for design = 1.5 bar [21.75 psi]

A proper filter design is made possible by our online “Bosch Rexroth FilterSelect” design software.

Oil viscosity:   
 ——— 140 mm<sup>2</sup>/s [649 SUS]   
 - - - 68 mm<sup>2</sup>/s [315 SUS]   
 - - - 30 mm<sup>2</sup>/s [143 SUS]

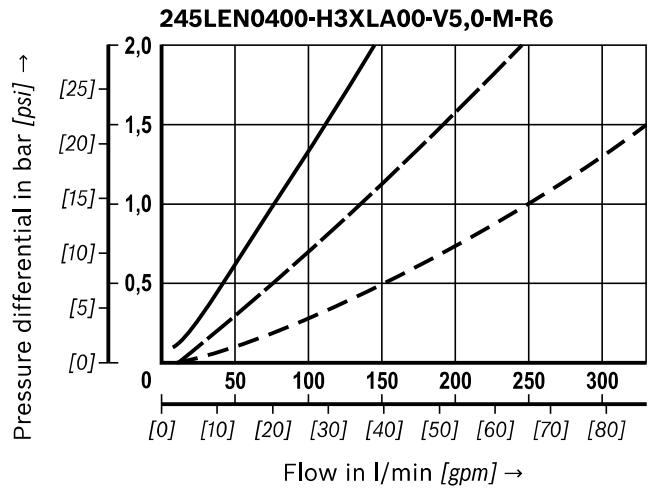
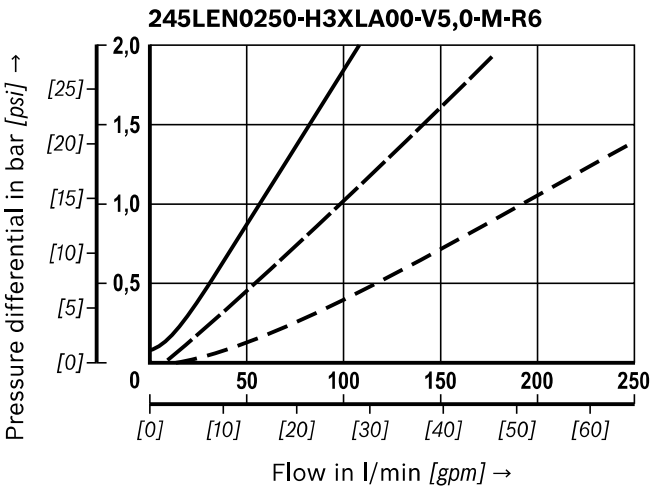
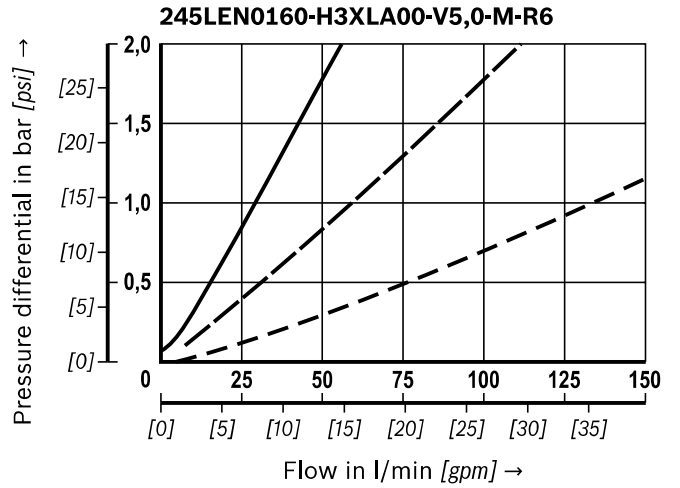
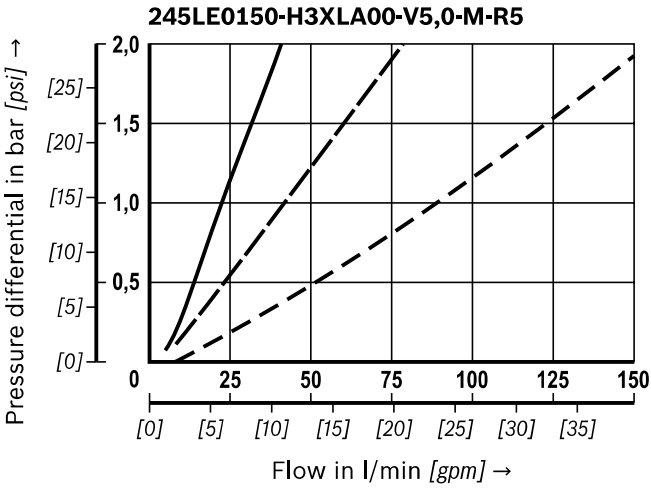

**Characteristic curves**

(measured with mineral oil HLP46 according to ISO 3968)

Spec. weight: < 0.9 kg/dm<sup>3</sup> Δp-Q-characteristic curves for complete filters recommended initial Δp for design = 1.5 bar [21.75 psi]

A proper filter design is made possible by our online “Bosch Rexroth FilterSelect” design software.

Oil viscosity:   
 ——— 140 mm<sup>2</sup>/s [649 SUS]   
 - - - 68 mm<sup>2</sup>/s [315 SUS]   
 - - - 30 mm<sup>2</sup>/s [143 SUS]

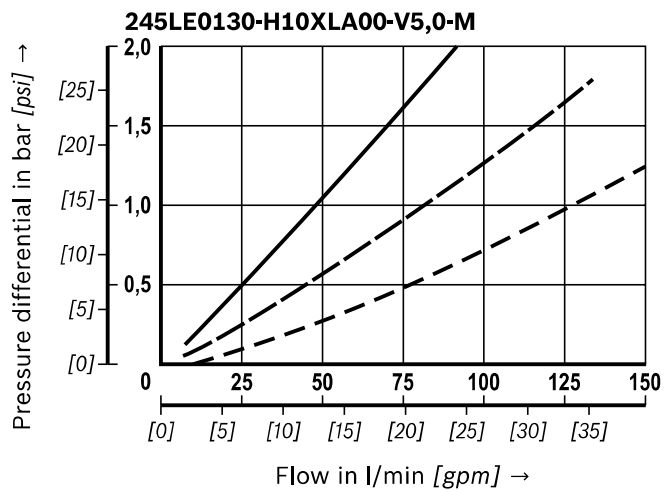
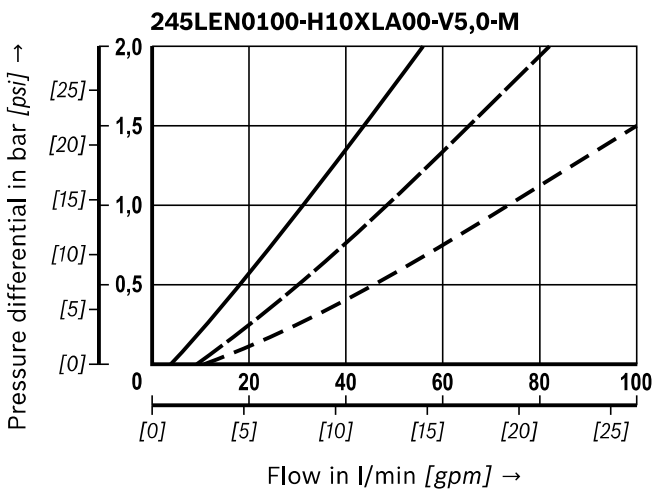
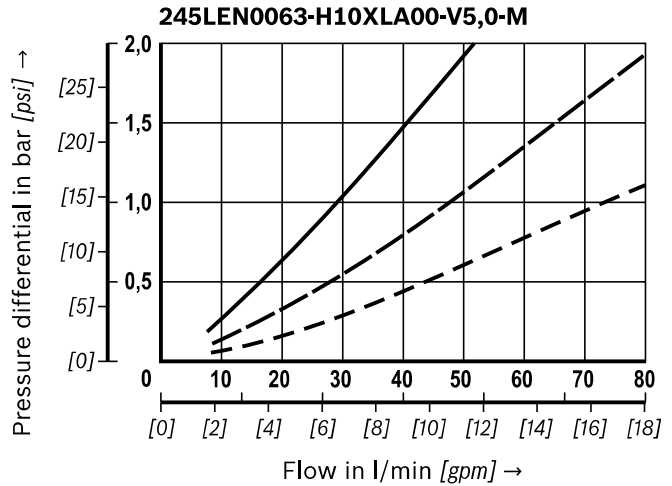
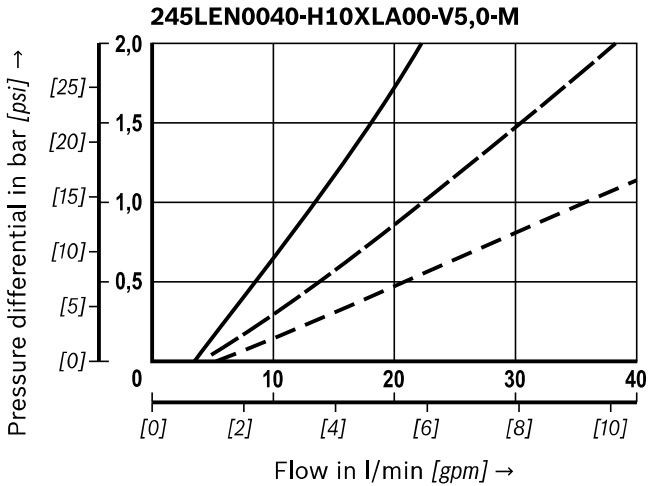

**Characteristic curves**  
(measured with mineral oil HLP46 according to ISO 3968)

**H10XL**

Spec. weight: < 0.9 kg/dm<sup>3</sup>

$\Delta p$ -Q-characteristic curves for complete filters recommended  
initial  $\Delta p$  for design = 1.5 bar [21.75 psi]

A proper filter design is made possible by our online  
“Bosch Rexroth FilterSelect” design software.

Oil viscosity:   
 ——— 140 mm<sup>2</sup>/s [649 SUS]  
 - - - 68 mm<sup>2</sup>/s [315 SUS]  
 - - - 30 mm<sup>2</sup>/s [143 SUS]

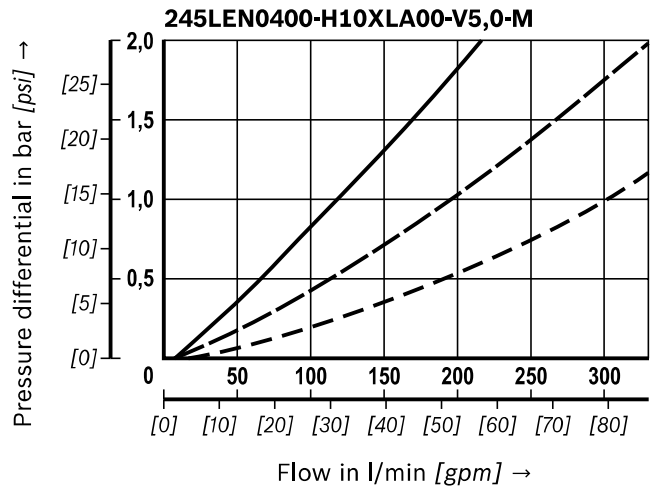
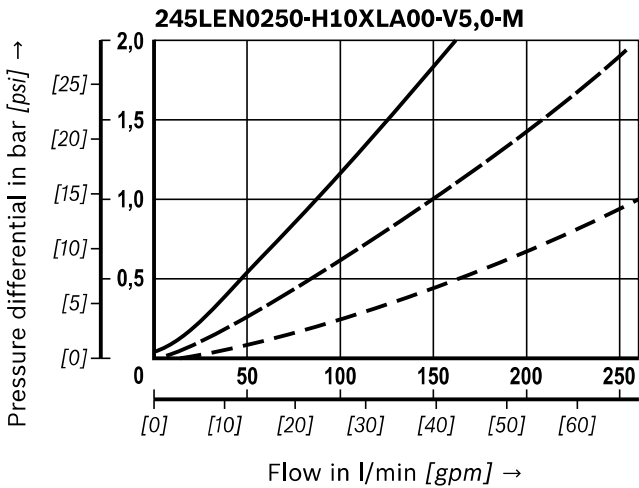
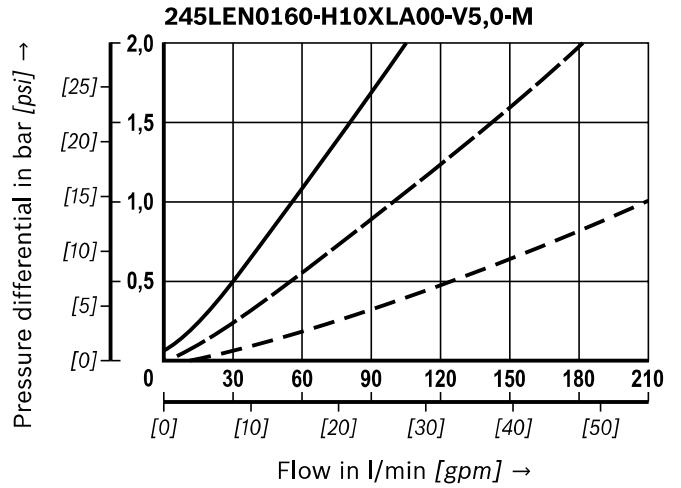
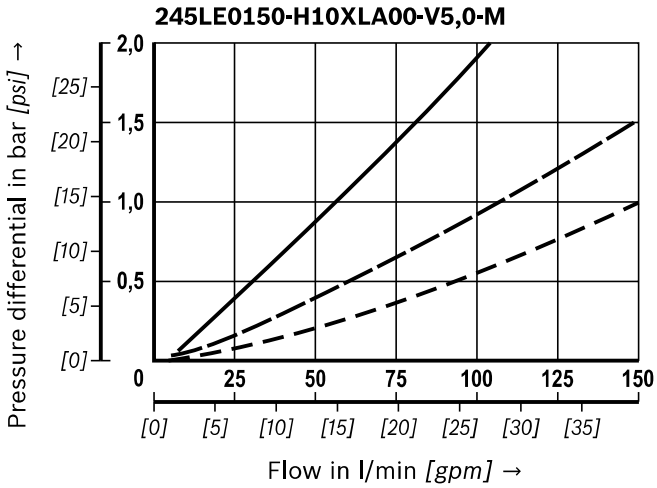

**Dimensions: 245LE(N) NG0040 ... NG0400**  
(Dimensions in mm [inch])

Pipe thread  
connections  
UNF thread

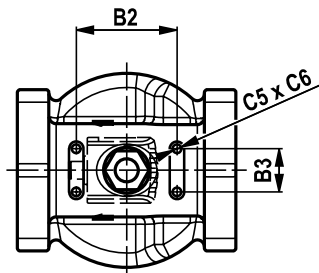
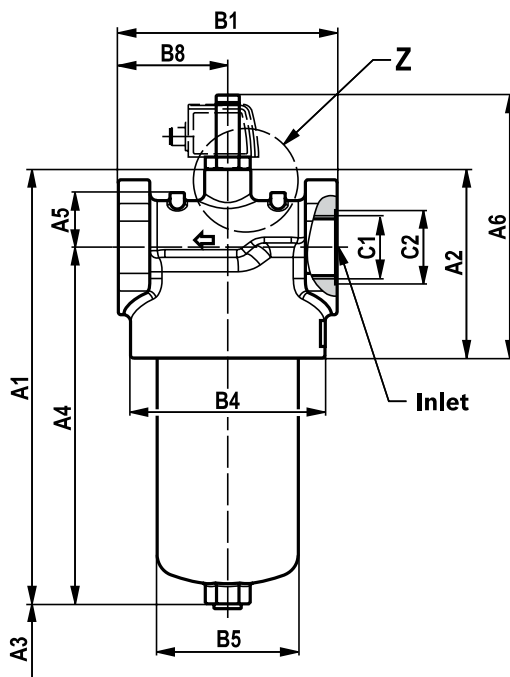

Connection SAE 1 1/2"  
- 3000 psi

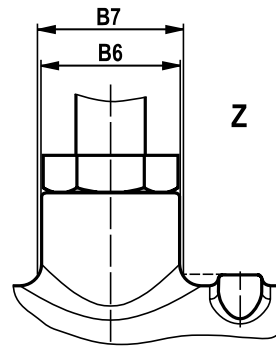
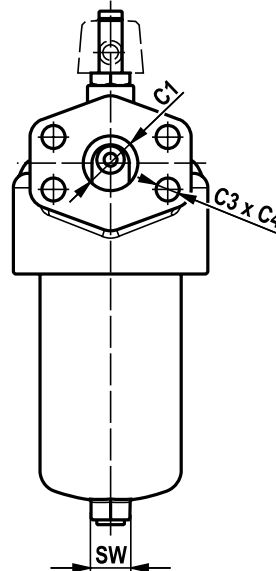

**Dimensions: NG0040 ... NG0400**  
 (Dimensions in mm [inch])

Type	A1	A2	A3 <sup>1)</sup>	A4	A5	A6
245LEN0040	200 [7.87]	94 [3.70]	120 [4.72]	156 [6.14]	25 [0.98]	146 [5.75]
245LEN0063	264 [10.39]			220 [8.66]		
245LEN0100	354 [13.94]			310 [12.20]		
245LE0130	324 [12.76]	121 [4.76]	140 [5.51]	270 [10.63]	38 [1.50]	173 [6.81]
245LE0150	374 [14.72]			320 [12.60]		
245LEN0160	356 [14.02]	131 [5.16]	120 [4.72]	302 [11.89]		183 [7.20]
245LEN0250	392 [15.43]			338 [13.31]		
245LEN0400	542 [21.34]			488 [19.21]		

Type	B1 <sup>2)</sup>	B2	B3	ØB4	ØB5	ØB6	ØB7	B8
245LEN0040	92 [3.62]	60 [2.36]	25 [0.98]	85 [3.35]	55 [2.17]	32 [1.26]	34 [1.34]	46 [1.81]
245LEN0063								
245LEN0100								
245LE0130	122 [4.80]	80 [3.15]	30 [1.18]	116 [4.57]	77 [3.03]		32 [1.26]	61 [2.40]
245LE0150								
245LEN0160	152 [5.98]	70 [2.76]	135 [5.31]	98 [3.86]	76 [2.99]			
245LEN0250								
245LEN0400								

Type	C1 connection					C3	C4	C5	C6	SW	
	Standard R...	ØC2	Optional U...	ØC2	Optional S...						
245LEN0040	G1/2	28 [1.10]	SAE 10 7/8-14 UNF-2B	41 [1.61]	-	M16	22 [0.87]	M6	8 [0.31]	19 [0.75]	
245LEN0063	G1	41 [1.61]	SAE 12 1 1/16-12 UN-2B								
245LEN0100											
245LE0130	G1 1/4	51 [2.01]	SAE 20 1 5/8-12 UN-2B	58 [2.28]						SAE 1 1/2" 3000 psi	24 [0.94]
245LE0150											
245LEN0160	G1 1/2	56 [2.20]	SAE 24 1 7/8-12 UN-2B	65 [2.56]	27 [1.06]						
245LEN0250											
245LEN0400											

<sup>1)</sup> Servicing height for filter element exchange

<sup>2)</sup> Dimension B1 is reduced with SAE flanges by 4 mm [0.16 inch]

## Maintenance indicator (dimensions in mm [inch])

Pressure differential indicator with mounted switching element M12 x 1

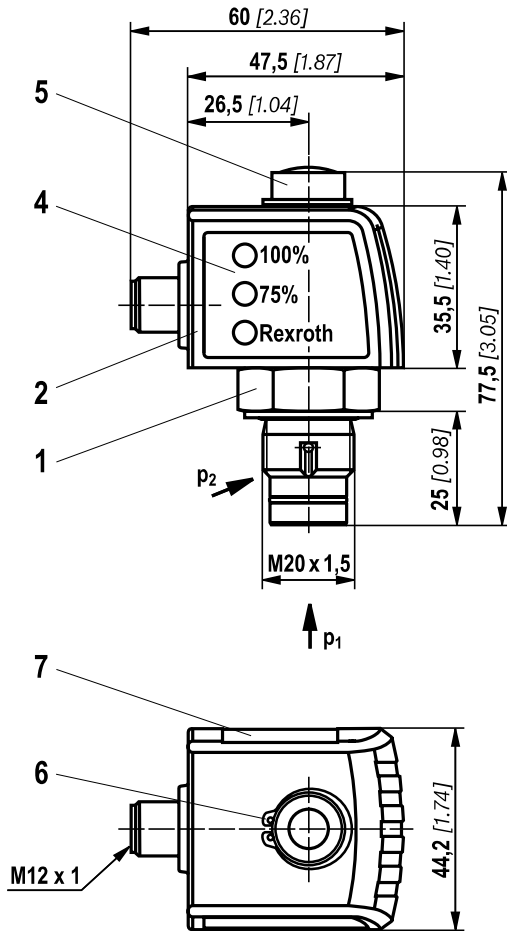

Pressure differential indicator with mounted switching element EN-175301-803

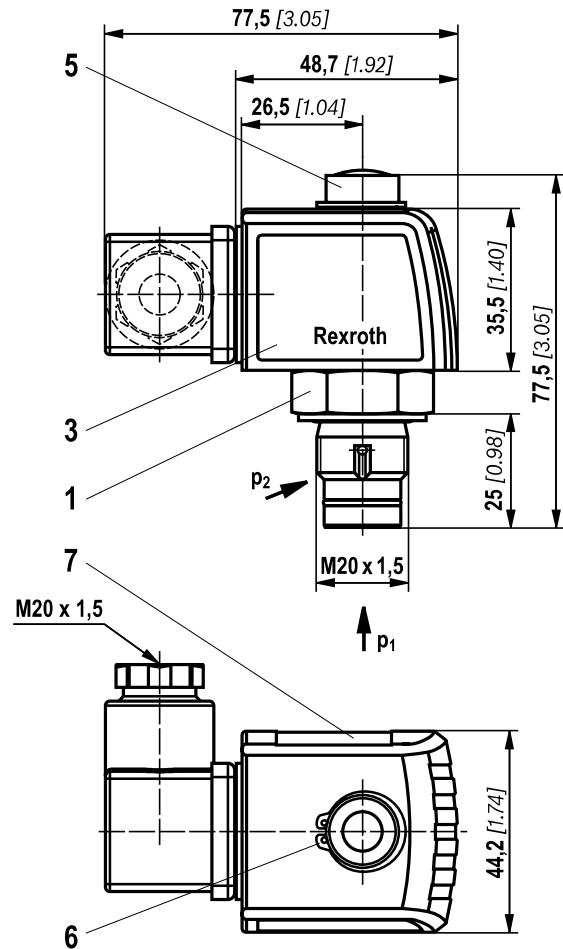

- 1 Mechanical optical maintenance indicator; max. tightening torque  $M_{A \max} = 50 \text{ Nm}$  [36.88 lb-ft]
- 2 Switching element with locking ring for electrical maintenance indicator (rotatable by 360°); round plug-in connection M12 x 1, 4-pole
- 3 Switching element with locking ring for electrical maintenance indicator (rotatable by 360°); rectangular plug-in connection EN175301-803
- 4 Housing with three LEDs: 24 V =  
green: Stand-by  
yellow: Switching point 75%  
red: Switching point 100%
- 5 Visual indicator bistable
- 6 Locking ring DIN 471-16 x 1, **material no. R900003923**
- 7 Name plate

### Notices:

Representation contains mechanical optical maintenance indicator (1) and electronic switching element (2) (3).

## Ordering code spare parts

### Filter element

01	02	03	04	05	06
2.			-	-	0

### Filter element

01	Design	2.
----	--------	----

### Size

02	LEN...	0040 0063 0100 0160 0250 0400
	LE...	0130 0150

### Filter rating in µm

03	<b>Absolute</b> (ISO 16889; $\beta_x(c) \geq 200$ )	Glass fiber material, not cleanable	H3XL H6XL H10XL H20XL
	<b>Nominal</b>	Stainless steel wire mesh, cleanable	G10 G25 G40 G60 G100

### Pressure differential

04	Max. admissible pressure differential of the filter element 30 bar [435 psi] – Filter <b>with</b> bypass valve	A00
	Max. admissible pressure differential of the filter element 330 bar [4786 psi] – Filter <b>without</b> bypass valve	B00

### Bypass valve

05	<b>without</b> bypass valve	0
----	-----------------------------	---

### Seal

06	NBR seal	M
	FKM seal	V

### Order example:

2,0100 H3XL-A00-0-M

For detailed information on Rexroth filter elements please refer to data sheet 51420.

### Preferred program replacement filter element

Replacement filter element 3 micron		Replacement filter element 6 micron		Replacement filter element 10 micron	
R928006645	2,0040 H3XL-A00-0-M	R928006646	2,0040 H6XL-A00-0-M	R928006647	2,0040 H10XL-A00-0-M
R928006699	2,0063 H3XL-A00-0-M	R928006700	2,0063 H6XL-A00-0-M	R928006701	2,0063 H10XL-A00-0-M
R928006753	2,0100 H3XL-A00-0-M	R928006754	2,0100 H6XL-A00-0-M	R928006755	2,0100 H10XL-A00-0-M
R928022274	2,0130 H3XL-A00-0-M	R928022275	2,0130 H6XL-A00-0-M	R928022276	2,0130 H10XL-A00-0-M
R928022283	2,0150 H3XL-A00-0-M	R928022284	2,0150 H6XL-A00-0-M	R928022285	2,0150 H10XL-A00-0-M
R928006807	2,0160 H3XL-A00-0-M	R928006808	2,0160 H6XL-A00-0-M	R928006809	2,0160 H10XL-A00-0-M
R928006861	2,0250 H3XL-A00-0-M	R928006862	2,0250 H6XL-A00-0-M	R928006863	2,0250 H10XL-A00-0-M
R928006915	2,0400 H3XL-A00-0-M	R928006916	2,0400 H6XL-A00-0-M	R928006917	2,0400 H10XL-A00-0-M

## Ordering code spare parts

### Mechanical optical maintenance indicator

01	02	03	04	05	06
<b>W</b>	<b>O</b>	<b>-</b>	<b>D01</b>	<b>-</b>	<b>-</b>

01	Maintenance indicator	<b>W</b>
----	-----------------------	----------

02	Mechanical optical indicator	<b>O</b>
----	------------------------------	----------

### Version

03	Pressure difference, modular design	<b>D01</b>
----	-------------------------------------	------------

### Switching pressure

04	2.2 bar [32 psi]	<b>2,2</b>
	5.0 bar [72.5 psi]	<b>5,0</b>

### Seal

05	NBR seal	<b>M</b>
	FKM seal	<b>V</b>

### Max. operating pressure

06	Switching pressure 2.2 bar [32 psi], 160 bar [2321 psi]	<b>160</b>
	Switching pressure 5.0 bar [72.5 psi], 450 bar [6527 psi]	<b>450</b>

Mechanical optical maintenance indicator	Material no.
WO-D01-2.2-M-160	<b>R901025312</b>
WO-D01-2.2-V-160	<b>R901066233</b>
WO-D01-5,0-M-450	<b>R901025313</b>
WO-D01-5,0-V-450	<b>R901066235</b>

**Ordering code  
spare parts**

**Seal kit**

01	02	03	04
<b>D</b>	<b>245LE</b>		-

01	Seal kit	<b>D</b>
----	----------	----------

02	Series	<b>245LE</b>
----	--------	--------------

**Size**

03	NG0040-0100	<b>N0040-0100</b>
	Size 0130-0150	<b>0130-0150</b>
	NG0160-0400	<b>N0160-0400</b>

**Seal**

04	NBR seal	<b>M</b>
	FKM seal	<b>V</b>

Material no.	Seal kit
<b>R928028016</b>	D245LEN0040-0100-M
<b>R928028214</b>	D245LE0130-0150-M
<b>R928028017</b>	D245LEN0160-0400-M
<b>R928047988</b>	D245LEN0040-0100-V
<b>R928048951</b>	D245LE0130-0150-V
<b>R928039838</b>	D245LEN0160-0400-V

## Assembly, commissioning, maintenance

### Installation

- ▶ The max. operating pressure of the system must not exceed the max. admissible operating pressure of the filter (see type plate).
- ▶ During assembly of the filter (see also chapter “Tightening torque”), the flow direction (direction arrows) and the required servicing height of the filter element (see chapter “Dimensions”) are to be considered.
- ▶ Easy filter element exchange is guaranteed in the installation position filter bowl vertically downwards. The maintenance indicator must be arranged so it is easily viewed in operation.
- ▶ Remove the plastic plugs in the filter inlet and outlet.
- ▶ Ensure that the system is assembled without tension stress.
- ▶ The optional electronic maintenance indicator is connected via the electronic switching element with 1 or 2 switching points, which is attached to the mechanical optical maintenance indicator and held by means of the locking ring.

### Commissioning

- ▶ Commission the system.

#### Notice:

There is no bleed function provided at the filter.

### Maintenance

- ▶ If at operating temperature, the red indicator pin reaches out of the mechanical optical maintenance indicator and/or if the switching process in the electronic switching element is triggered, the filter element is contaminated and needs to be replaced and cleaned respectively.  
More details see data sheet 51450
- ▶ The material number of the corresponding replacement filter element is indicated on the name plate of the complete filter. It must comply with the material number on the filter element.
- ▶ Decommission the system.
- ▶ The operating pressure is to be built up on the system side.

#### Notice:

There is no bleed function provided at the filter.

- ▶ Via the drain screw (from size 0160 fitted by default), the oil on the dirt side can be drained.
- ▶ Screw off the filter bowl.
- ▶ Remove the filter element from the spigot by rotating it slightly.
- ▶ Clean the filter components, if necessary.
- ▶ Check the seals at the filter bowl for damage and renew them, if necessary.  
For suitable seal kits refer to chapter “Spare parts”.
- ▶ Filter elements made of wire mesh can be cleaned. For detailed cleaning instructions refer to data sheet 51420.
- ▶ Install the new or cleaned filter element on the spigot again by slightly rotating it.
- ▶ The filter is to be assembled in reverse order.
- ▶ The torque specifications (Tightening torques chapter) are to be observed.
- ▶ Commission the system.

### WARNING!

- |  |   |
|--|---|
| <ul style="list-style-type: none"> <li>▶ Assemble and disassemble only with depressurized system!</li> <li>▶ Filter is pressurized!</li> <li>▶ Remove the filter bowl only if it is not under pressure!</li> <li>▶ Do not exchange the optical/mechanical maintenance indicator while the filter is under pressure!</li> </ul> | <ul style="list-style-type: none"> <li>▶ If the flow direction is not considered during assembly, the filter element will be destroyed. Particle contaminates could enter the system and damage the downstream components.</li> </ul> |
|--|---|

#### Notices:

- ▶ All maintenance of the filter should be performed by trained specialists.
- ▶ Proper function and safety are only guaranteed if original Bosch Rexroth filter elements and spare parts are used.
- ▶ Warranty becomes void if the delivered item is changed by the ordering party or third parties or improperly mounted, installed, maintained, repaired, used or exposed to environmental condition that do not comply with the installation conditions.

**Tightening torques**  
(dimensions in mm [inch])

**Mounting**

Series 245...	LEN0040	LEN0063	LEN0100	LE0130	LE0150	LEN0160	LEN0250	LEN0400
Screw/tightening torque with $\mu_{total} = 0.14$	M6 / 4.5 Nm $\pm$ 10%							
Quantity	4							
Recommended property class of screw	8.8							
Minimum screw-in depth	6 + 1 mm [0.24 + 0.04 in]							

**Filter bowl and maintenance indicator**

Series 245...	LEN0040	LEN0063	LEN0100	LE0130	LE0150	LEN0160	LEN0250	LEN0400
Tightening torque filter bowl	50 Nm + 10 Nm							
Tightening torque maintenance indicator	max. 50 Nm							
Tightening torque cubic connector screw switching element EN-175301-803	M3/0.5 Nm							

**Directives and standardization**

**Classification according to the Pressure Equipment Directive**

The inline filters for hydraulic applications according to 51421 are pressure holding equipment according to article 1, section 2.1.4 of the Pressure Equipment Directive 97/23/EC (PED). However, based on the exception in article 1, section 3.6 of the PEG, hydraulic filters are

exempt from the PED if they are not classified higher than category I (guideline 1/19).

The fluids from the chapter “Compatibility with approved pressure fluids” were considered for the classification. They do not receive a CE mark.

**Use in explosive areas according to directive 94/9/EC (ATEX)**

The inline filters according to 51421 are no equipment or components in the sense of directive 94/9/EC and are not provided with a CE mark. It has been proven with the ignition risk analysis that these inline filters do not have own ignition sources acc. to DIN EN 13463-1:2009.

According to DIN EN 60079-11:2012, electronic maintenance indicators with a switching point:

WE-1SP-M12 x 1 **R928028409**

WE-1SP-EN175301-803 **R928036318**

are simple, electronic operating equipment that do not have an own voltage source. This simple, electronic operat-

ing equipment may - according to DIN EN 60079-14:2012 - in intrinsically safe electric circuits (Ex ib) be used in systems without marking and certification.

The inline filters and the electronic maintenance indicators described here can be used for the following potentially explosive areas:

	zone suitability	
Gas	1	2
Dust	21	22

**Directives and standardization**

Complete filter with mech./opt. Maintenance indicator				
Use /assignment		Gas 2G		Dust 2D
Assignment		Ex II 2G c IIC TX		Ex II 2D c IIC TX
Conductivity of the medium	pS/m	min	300	
Dust accumulation		max	-	0.5 mm

electronic switching element in the intrinsically safe electric circuit				
Use /assignment		Gas 2G		Dust 2D
Assignment		Ex II 2G Ex ib IIB T4 Gb		Ex II 2D Ex ib IIIC T100°C Db
perm. intrinsically safe electric circuits		Ex ib IIC, Ex ic IIC		Ex ib IIC
Technical data		Values only for intrinsically safe electric circuit		
Switching voltage	Ui	max	150 V AC/DC	
Switching current	li	max	1.0 A	
Switching power	Pi	max	1.3 W T4 T <sub>max</sub> 40 °C	750 mW T <sub>max</sub> 40 °C
		max	1.0 W T4 T <sub>max</sub> 80 °C	550 mW T <sub>max</sub> 100 °C
Surface temperature <sup>1)</sup>		max	-	100 °C
inner capacity	Ci		negligible	
inner inductivity	Li		negligible	
Dust accumulation		max	-	0.5 mm

<sup>1)</sup> The temperature depends on the temperature of the medium in the filter and must not exceed the value specified here.

Possible circuit according to DIN EN 60079-14

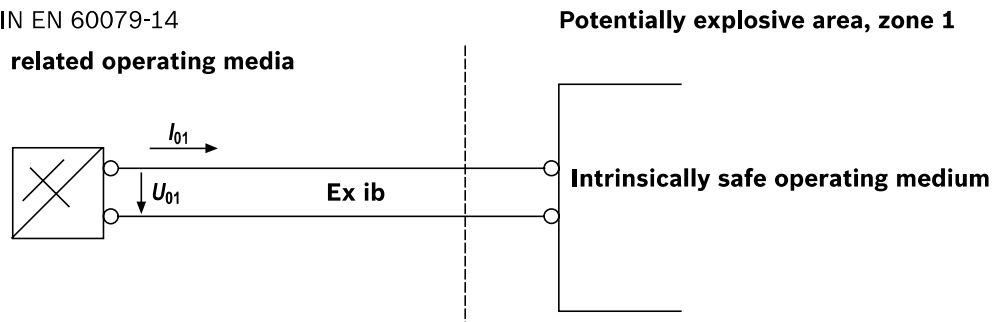

**⚠ WARNING!**

- ▶ Explosion hazard due to high temperature!  
The temperature depends on the temperature of the medium in the hydraulic circuit and must not exceed the value specified here. Measures are to be taken so that in the explosive area, the max. admissible ignition temperature is not exceeded.
- ▶ When using the inline filters in accordance with 51 421 in potentially explosive areas, appropriate equipo-  
tential bonding has to be ensured. The filter is preferably to be grounded via the mounting screws. It has to be noted in this connection that paintings and oxidic protective layers are not electrically conductive.
- ▶ During filter element exchanges, the packaging material is to be removed from the replacement element outside the explosive area

**👉 Notices:**

- ▶ Maintenance only by trained specialists, instruction by the machine end-user acc. to DIRECTIVE 1999/92/EC appendix II, section 1.1
- ▶ Warranty is only applicable when using genuine Rexroth spare parts

Bosch Rexroth AG  
Ketsch plant  
Hardtwaldstr. 43  
68775 Ketsch, Germany  
Telephone +49 (0) 62 02/603-0  
filter-support@boschrexroth.de  
www.boschrexroth.de

© This document, as well as the data, specifications and other information set forth in it, are the exclusive property of Bosch Rexroth AG. It may not be reproduced or given to third parties without the consent of Bosch Rexroth AG. The data specified above only serve to describe the product. No statements concerning a certain condition or suitability for a certain application can be derived from our information. The information given does not release the user from the obligation of own judgment and verification. It must be remembered that our products are subject to a natural process of wear and aging.

## Notes

Bosch Rexroth AG  
Ketsch plant  
Hardtwaldstr. 43  
68775 Ketsch, Germany  
Telephone +49 (0) 62 02 / 603-0  
filter-support@boschrexroth.de  
www.boschrexroth.de

© This document, as well as the data, specifications and other information set forth in it, are the exclusive property of Bosch Rexroth AG. It may not be reproduced or given to third parties without the consent of Bosch Rexroth AG. The data specified above only serve to describe the product. No statements concerning a certain condition or suitability for a certain application can be derived from our information. The information given does not release the user from the obligation of own judgment and verification. It must be remembered that our products are subject to a natural process of wear and aging.

## Notes

Bosch Rexroth AG  
Ketsch plant  
Hardtwaldstr. 43  
68775 Ketsch, Germany  
Telephone +49 (0) 62 02/603-0  
filter-support@boschrexroth.de  
www.boschrexroth.de

© This document, as well as the data, specifications and other information set forth in it, are the exclusive property of Bosch Rexroth AG. It may not be reproduced or given to third parties without the consent of Bosch Rexroth AG. The data specified above only serve to describe the product. No statements concerning a certain condition or suitability for a certain application can be derived from our information. The information given does not release the user from the obligation of own judgment and verification. It must be remembered that our products are subject to a natural process of wear and aging.